

The powerhouse of resolution

for CT inspection and metrology.

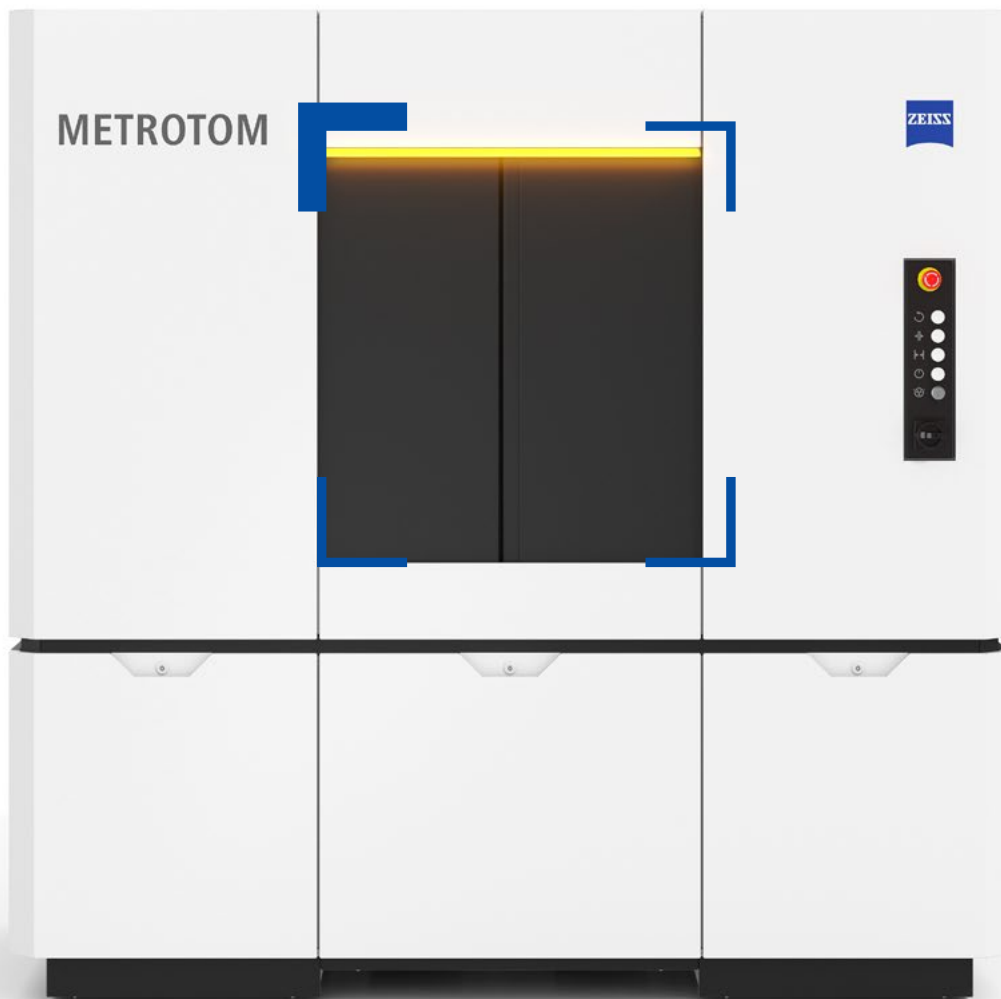

ZEISS METROTOM 6 scout



Enabling deep insights

ZEISS METROTOM 6 scout

Non-destructive measurements and inspections

ZEISS METROTOM 6 scout shows its strengths above all in the inspection of plastic parts. High-resolution images can be captured for precise measuring tasks or detailed inspections of internal structures. Be it shrinkage holes, pores, cracks, sink marks or warpage – all defects or deviations from the CAD model can be detected. Non-destructively!

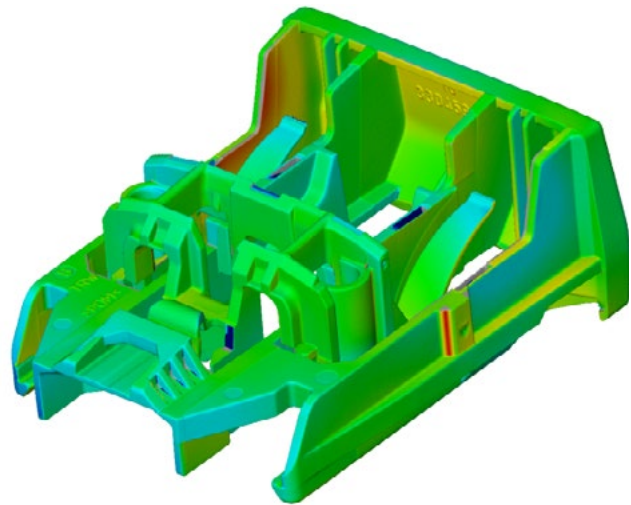

Nominal/actual comparison

Fast tool correction

When manufacturing plastic parts, many iteration loops are often necessary until the tools are correctly set-up or corrected. This process can be shortened by 30 - 70% thanks to computed tomography and the ZEISS REVERSE ENGINEERING software. To do this, volume data is first acquired with ZEISS METROTOM 6 scout. This comprehensive 3D data set can then be used in the software to convert deviations from the CAD model directly into a corrected tool shape.

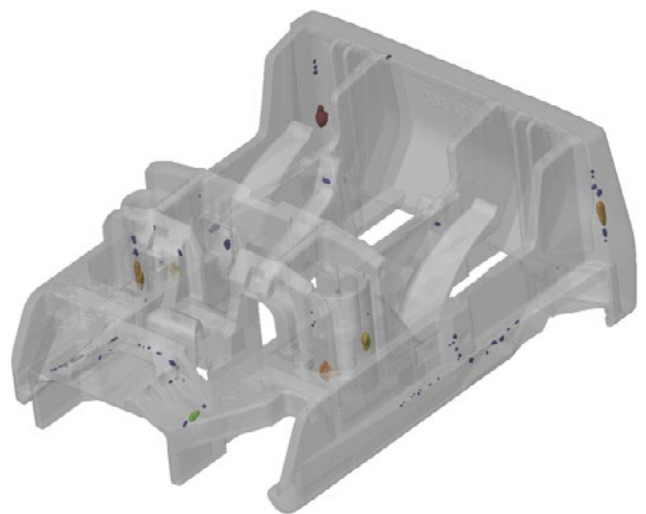

Defect analysis

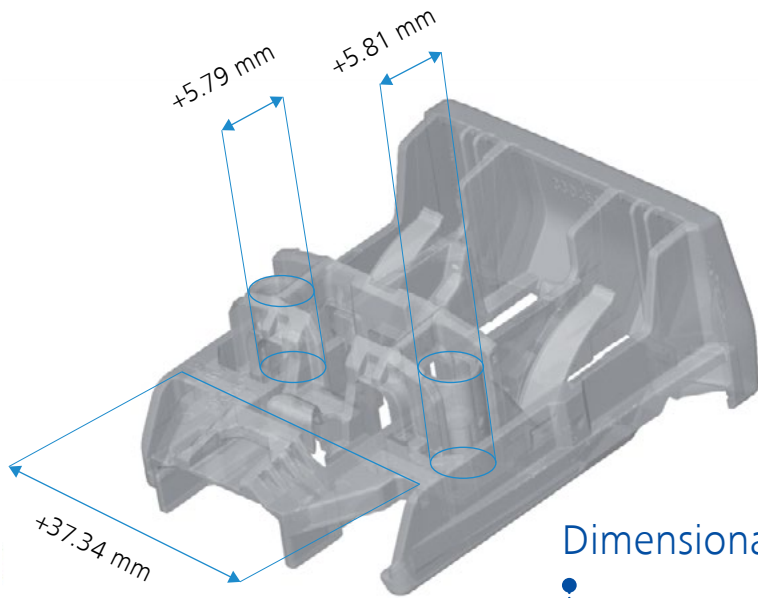

Dimensional control

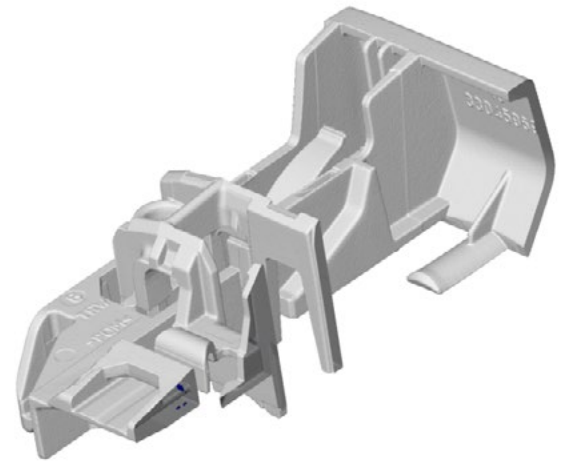

Sectional view

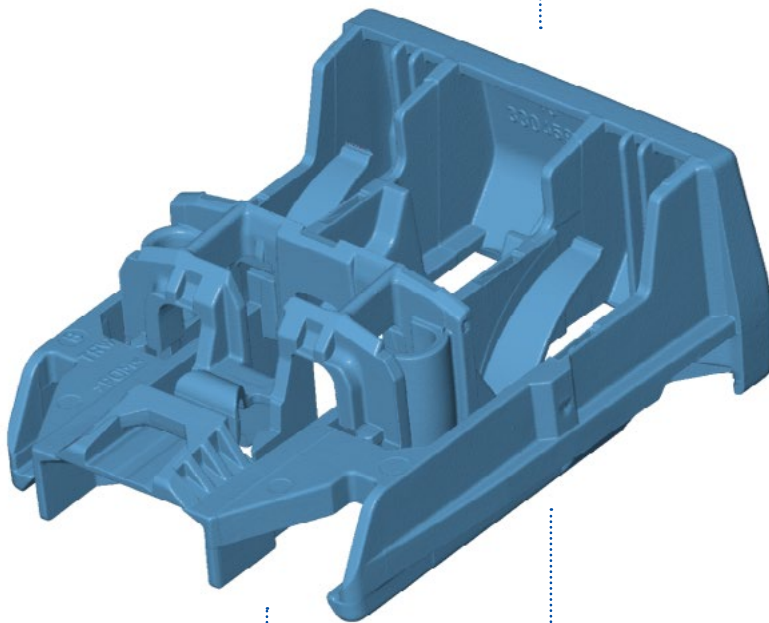

Wall thickness analysis

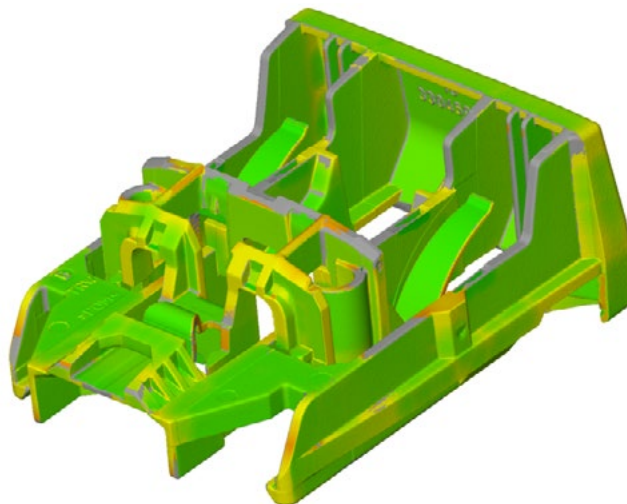

With high resolution to accurate measurement results

You need to measure your parts accurately or find the smallest defects on the inside? With ZEISS METROTOM 6 scout this is no problem at all. Thanks to the system's high accuracy and resolution, you can generate accurate and detailed measurement and inspection results.



Measure accurately

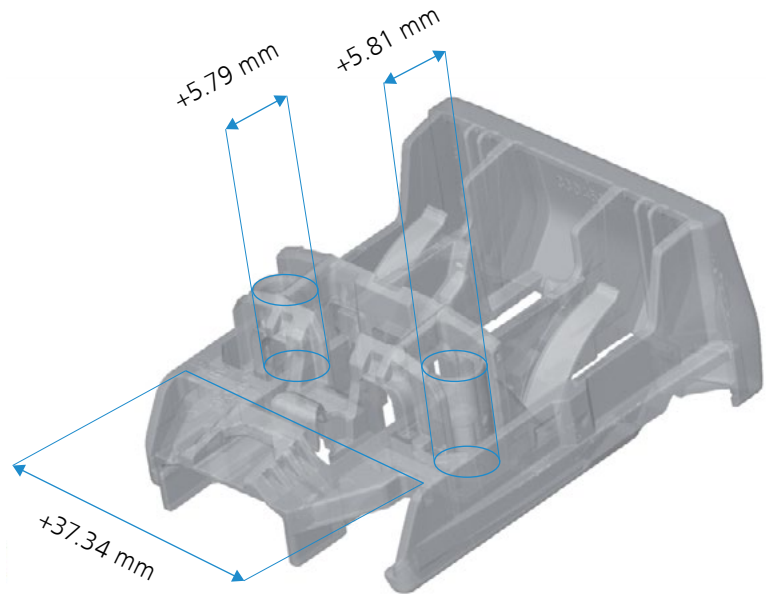

With ZEISS METROTOM 6 scout, reliable, highly accurate evaluations of part quality can be made on the basis of the measurement results. Additionally, you can carry out further analyses such as dimensional analyses, as well as wall thickness analyses or target/actual comparisons.

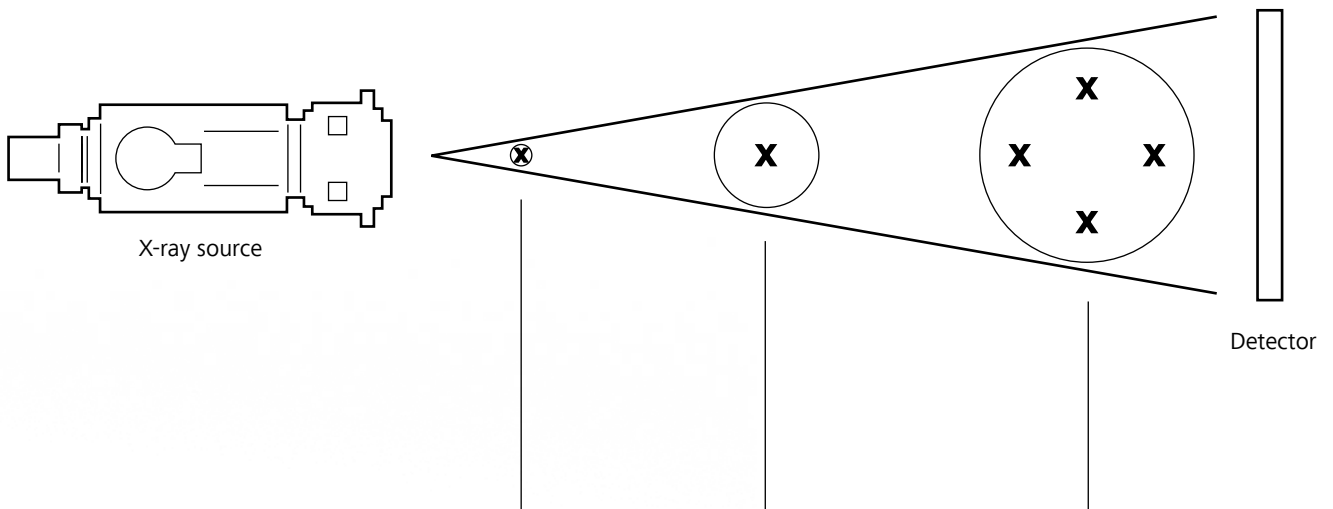

See every detail

The combination of a 3k detector and 225 kV X-ray source enables ZEISS METROTOM 6 scout to provide high-contrast, high-resolution measurement results and exceptional sharpness of detail. As a result, even the smallest defects in the part become visible and can be analyzed down to the last detail.



	Voxel size	3 μm	27 μm	80 μm
	Part diameter	10 mm	80 mm	240 mm

Easy to use

ZEISS METROTOM 6 scout



A 5-axis kinematics with integrated centering table helps you to optimally position the part in the measuring volume. You simply place it in the machine's measuring room – the rest is done by the software. In addition to simplified device operation, this guarantees that each part is measured in the

best possible measuring position and, thus, always with the highest possible resolution. Moreover, you save valuable time for the usually time-consuming alignment process of the part in the X-ray beam.

All-in-one software

ZEISS INSPECT X-Ray

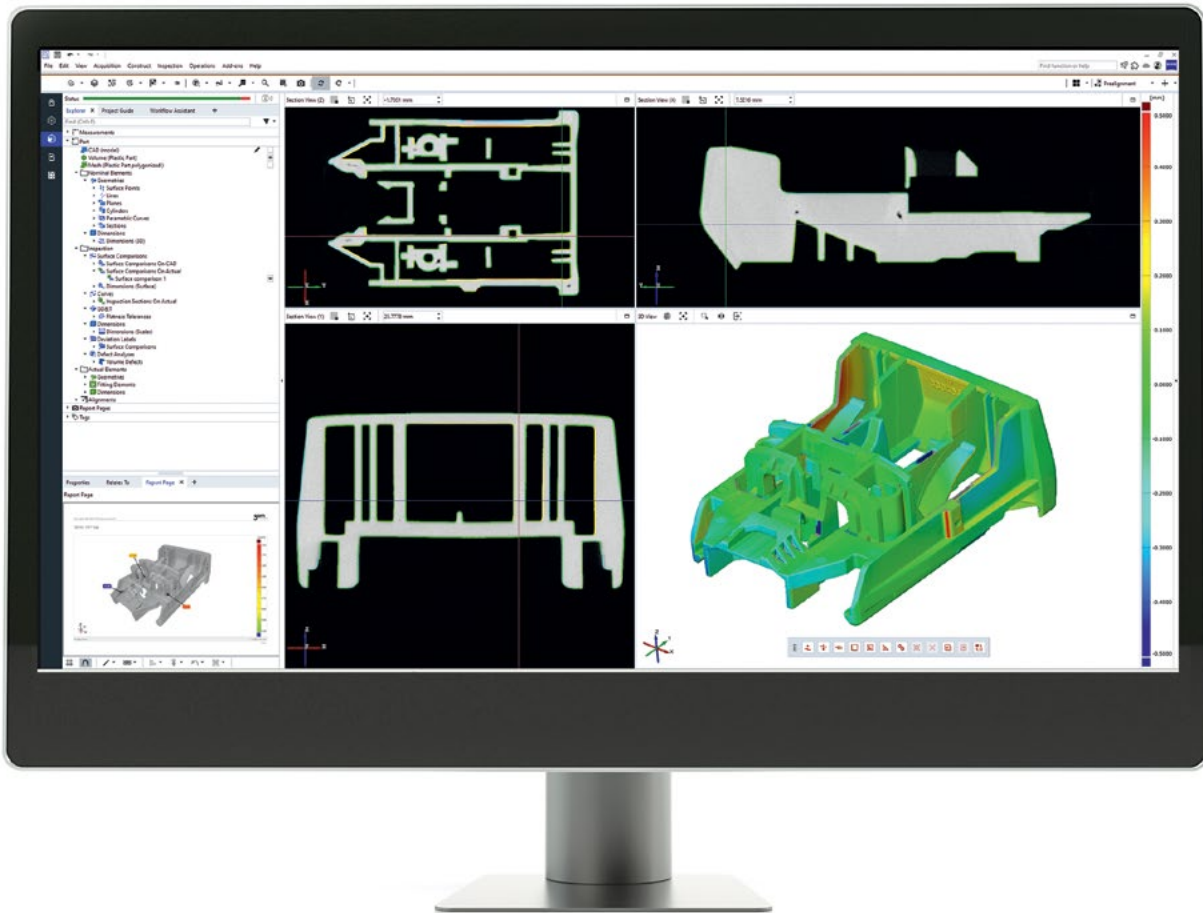

The control of the device and the metrological evaluation of the data are combined in a single software package, making additional software or intermediate steps redundant. The process chain from the recording of the raw data through the inspection up to the creation of a measuring report is significantly simplified with.

The detected defects can be analyzed in detail and automatically evaluated according to various criteria. In addition, you can load volume data of several components into a project, perform a trend analysis and compare the data with the CAD model.

Carl Zeiss

Industrielle Messtechnik GmbH

73446 Oberkochen / Germany

Sales: +49 7364 20-6336

Service: +49 7364 20-6337

Fax: +49 7364 20-3870

Email: info.metrology.de@zeiss.com

Internet: www.zeiss.de/metrotom-6-scout

Carl Zeiss

Industrial Metrology, LLC

6250 Sycamore Lane North

Maple Grove, MN 55369/USA

Phone: +1 763 744-2400

Fax: +1 763 533-0219

Email: info.metrology.us@zeiss.com

Internet: www.zeiss.com/metrotom-6-scout