

**ZEISS** Industrial Quality Solutions

# Portfolio

PRODUCTS | SPRING 2026





# Content

## 1

---

### Coordinate Measuring Machines

Bridge CMMs . . . . .	04
Large CMMs . . . . .	07
Shop Floor CMMs . . . . .	08
Optical CMMs . . . . .	10
Horizontal arm CMMs . . . . .	12
ZEISS CALYPSO . . . . .	14
Tactile Probes . . . . .	16
Optical Probes . . . . .	18
Roughness Sensor . . . . .	19
Integration Series . . . . .	20

---

## 2

---

### Optical Systems

Optical 3D Metrology . . . . .	24
3D Scanning . . . . .	25
HandsOnMetrology . . . . .	26
ZEISS CORRELATE . . . . .	28
3D Photogrammetry . . . . .	29
3D Testing . . . . .	29
Automated Solutions . . . . .	30
ZEISS INSPECT Optical 3D . . . . .	34

---

## 3

---

### X-Ray

2D X-Ray . . . . .	36
3D X-Ray . . . . .	38
ZEISS INSPECT X-Ray . . . . .	42

---

## 4

---

### Industrial Microscopes

Stereo and Zoom Microscopes . . . . .	44
Digital and Laser Scanning Microscopes . . . . .	46
Wide Field Microscopes . . . . .	48
Scanning Electron Microscopes . . . . .	50
X-Ray Microscopes . . . . .	52
ZEISS ZEN core . . . . .	54

---

## 5

---

### Software

ZEISS CONNECTED QUALITY . . . . .	56
ZEISS PiWeb . . . . .	57

---

## 6

---

### Services

Service & Support . . . . .	58
-----------------------------	----

---



Sustainable product

## Bridge-Type CMMs

Bridge-type coordinate measuring machines (CMMs) are engineered to meet the demanding challenges of industrial measurement technology, delivering precise results with minimal deviations. Designed for exceptional accuracy and reliability, these machines ensure strict production quality control and are adaptable to a wide range of applications. Tailored solutions can be customized to meet your specific requirements.



## ZEISS SPECTRUM family

With ZEISS SPECTRUM family – consisting of ZEISS SPECTRUM and ZEISS SPECTRUM verity, you will enter the next level of flexibility and performance. Trust your parts due to more reliability in the measurement results.

### ZEISS SPECTRUM

Upgrading to the next level in identifying defect parts by scanning complex geometry and surface. ZEISS SPECTRUM offers tactile scanning and the new optical sensor ZEISS LineScan One.

### ZEISS SPECTRUM verity

ZEISS SPECTRUM verity in combination with the sensor ZEISS VAST XT gold opens the world for active scanning. The coordinate measuring machine offers more reliability, stability, capability, and flexibility.

#### Technical Specification

Bildoptimierung AC tech – Zeynep OKMeasuring Volume X/Y/Z from 7/7/6 to 9/18/6

- Accuracy E0 in  $\mu\text{m}$  from  $1.7 + L/300$



## ZEISS CONTURA

It is equipped with the mass technology and, thanks to a common interface, enables simple switching between different sensor technologies in just a few simple steps.

#### Technical Specification

- Measuring Volume X/Y/Z from 7/7/6 to 12/24/10
- Accuracy E0 in  $\mu\text{m}$   $1.4 + L/350$



## ZEISS MICURA

Despite its small size, ZEISS MICURA makes no compromises when it comes to accuracy. It is equipped with the VAST XTR gold scanning sensor and VAST navigator technology.

#### Technical Specification

- Measuring Volume X/Y/Z 5/7/6
- Accuracy E0 in  $\mu\text{m}$   $0.7 + L/400$



## ZEISS PRISMO family

For more than 30 years, ZEISS PRISMO has been synonymous worldwide with high-speed scanning and maximum accuracy. PRISMO from ZEISS fully complies with ISO quality standards – a must in a world where precision matters the most.

### ZEISS PRISMO

Besides the aspiration of not accepting compromises when it comes to precision, ZEISS PRISMO is ideal when maximum demands on precision have to be met.

### ZEISS PRISMO fortis

ZEISS PRISMO fortis guarantees maximum precision in production environments at high temperatures of up to 40°C.

### ZEISS PRISMO verity

Manufactured with the know-how from PRISMO ultra, ZEISS PRISMO verity provides a high level of accuracy and has an extended temperature range.

### ZEISS PRISMO ultra

ZEISS PRISMO ultra represents the most accurate machine of the ZEISS PRISMO family.

#### Technical Specification

- Measuring Volume X/Y/Z from 7/9/5 to 16/42/14
- Accuracy E0 in  $\mu\text{m}$  from 0.9 + L/350 (PRISMO) / 0.7 + L/400 (at 22°C) up to 2.7 + L/80 (at 40°C) (PRISMO fortis) / 0.7 + L/400 (PRISMO verity) / 0.5 + L/500 (PRISMO ultra)

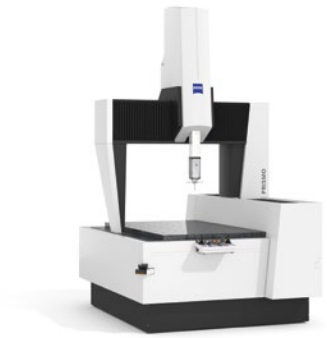

## ZEISS XENOS

ZEISS XENOS combines precision at the limits of what is technically feasible with a measuring range of nearly one cubic meter.

#### Technical Specification

- Measuring Volume X/Y/Z 9/15/7
- Accuracy E0 in  $\mu\text{m}$  0.2 + L/1000



# Large CMMs

CMMs with extensive measuring ranges and high load capacities are essential in industries such as energy, power generation, mechanical engineering, and aerospace. The ZEISS MMZ product family offers configurable solutions of various sizes designed to measure even the largest workpieces while maintaining uncompromising accuracy.

## ZEISS MMZ family

### ZEISS MMZ 1 table

ZEISS MMZ 1 table is suitable for all applications where accurate contact measurements are needed and where size, form and location measurements are evaluated with the highest accuracy – with the probe head ZEISS VAST XT gold.

Technical Specification

- Measuring Volume X/Y/Z 20/30/15 and 20/40/15
- Accuracy E0 in  $\mu\text{m}$   $3.6 + L/250$



### ZEISS MMZ T

With a measuring range of up to  $14.8 \text{ m}^3$ , ZEISS MMZ T offers the largest measuring range from amongst the table bridge-type measuring machines.

Technical Specification

- Measuring Volume X/Y/Z from 21/32/12 to 21/44/16, other on NSP request possible
- Accuracy E0 in  $\mu\text{m}$   $2.4 + L/400$



### ZEISS MMZ M

Precise measurement at economical acquisition costs - that was the aim when developing ZEISS MMZ M. The device is ideal for inspecting complex and, above all, medium-sized workpieces with tight tolerances.

Technical Specification

- Measuring Volume X/Y/Z from 20/30/12 to 30/60/20
- Accuracy E0 in  $\mu\text{m}$   $2.2 + L/400$



### ZEISS MMZ G

ZEISS MMZ G meets the highest demands: the system features the largest measuring range of all measuring machines offered by ZEISS and provides you with unparalleled accuracy.

Technical Specification

- Measuring Volume X/Y/Z from 30/50/12 to 60/100/35, other on NSP request possible
- Accuracy E0 in  $\mu\text{m}$   $2.6 + L/400$

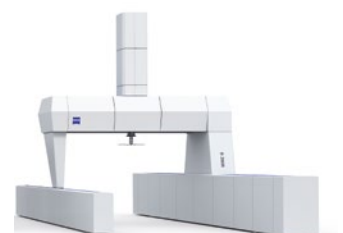



# Shop Floor CMMs

Shop floor CMMs are specifically designed to perform reliable measurements directly in production environments, where factors like dust, oil, floor vibrations, and temperature fluctuations can pose challenges. The shop floor CMMs from ZEISS are built to withstand these conditions and enable precise quality assurance at the site of manufacturing. This way, errors can be quickly identified or prevented entirely.

## ZEISS DuraMax

ZEISS DuraMax is equipped with the VAST XXT scanning sensor from ZEISS. It can even be used to capture contours and freeform surfaces. A rough production environment is no challenge for ZEISS DuraMax. Sustainability is a principle of action for the use of resources.

Technical Specification

- Measuring Volume X/Y/Z 5/5/5
- Accuracy E0 in  $\mu\text{m}$  2.4 + L/300



## ZEISS DuraMax HTG

ZEISS DuraMax HTG has the widest temperature range and highest temperature gradient, making it suitable for use in production sites and automation systems with more resistance to environmental influences.

Technical Specification

- Measuring Volume X/Y/Z 5/5/5
- Accuracy E0 in  $\mu\text{m}$  2.2 + L/300



## ZEISS PRISMO fortis

ZEISS PRISMO fortis delivers reliable measurements under the harshest conditions, even at temperatures of up to 40°C. For this reason, ZEISS PRISMO fortis can be integrated into production without additional investment in a measuring room.

Technical Specification

- Measuring Volume X/Y/Z from 7/12/7 to 12/18/10
- Accuracy E0 in  $\mu\text{m}$  from 0.7 + L/400 (at 22°C) up to 2.7 + L/80 (at 40°C)



## Optical CMMs

Optical CMMs are ideal for applications where tactile metrology is limited by product design or material sensitivity. They enable precise, non-contact measurement of sensitive, thin-walled, or flat workpieces, such as optics, foils, and injection-molded parts. The ZEISS Optical Series can also be supplemented with tactile probes, offering a versatile solution for both optical and tactile measurements in a single system.



## ZEISS O-DETECT

Intuitive operation, high-quality camera and flexible lighting for precise measurements. Suitable for a wide variety of components, but mainly for those that are better left untouched.

### Main Applications

- Mainly optical 2D measurements of parts of any color and surface finish. From colored plastics and electronic parts up to reflecting medical parts.

### Technical Specification

- Measuring Volume X/Y/Z from 3/2/2 to 5/4/3
- Accuracy E0 in  $\mu\text{m}$  from: 1D:  $1.6 + L/200$ , 2D:  $1.9 + L/150$ , 3D:  $2.4 + L/150$

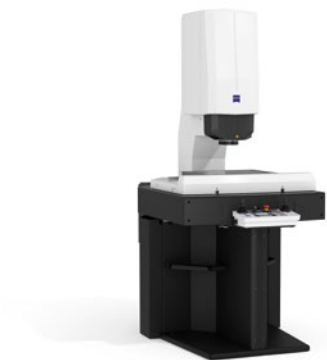

## ZEISS O-INSPECT

The O-INSPECT multi-sensor measuring machine from ZEISS enables you to optimally measure each characteristic with optical or tactile measurements. Special feature: ZEISS O-INSPECT delivers reliable 3D measurements compliant with ISO standards at a temperature range of 18–30 °C.

### Main Applications

- Workpieces with sensitive surfaces and with real 3D features and tight tolerances where tactile scanning is a benefit.

### Technical Specification

- Measuring Volume X/Y/Z from 3/2/2 to 8/6/3
- Accuracy E0 in  $\mu\text{m}$  from: 1D:  $1,4 + L/250$ , 2D:  $1,6 + L/250$ , 3D:  $1,9 + L/250$





## **Horizontal Arm CMMs**

Horizontal arm CMMs are designed to deliver optimal measurement results through maximum accessibility. Featuring a fixed bridge and a movable axis, these machines provide a large measuring range, making them ideal for inspecting sheet metal, cast iron, or steel components in industries such as automotive, aerospace, and shipbuilding. Their design ensures precise measurement of even large workpieces, minimizing deviations and enabling reliable quality control.

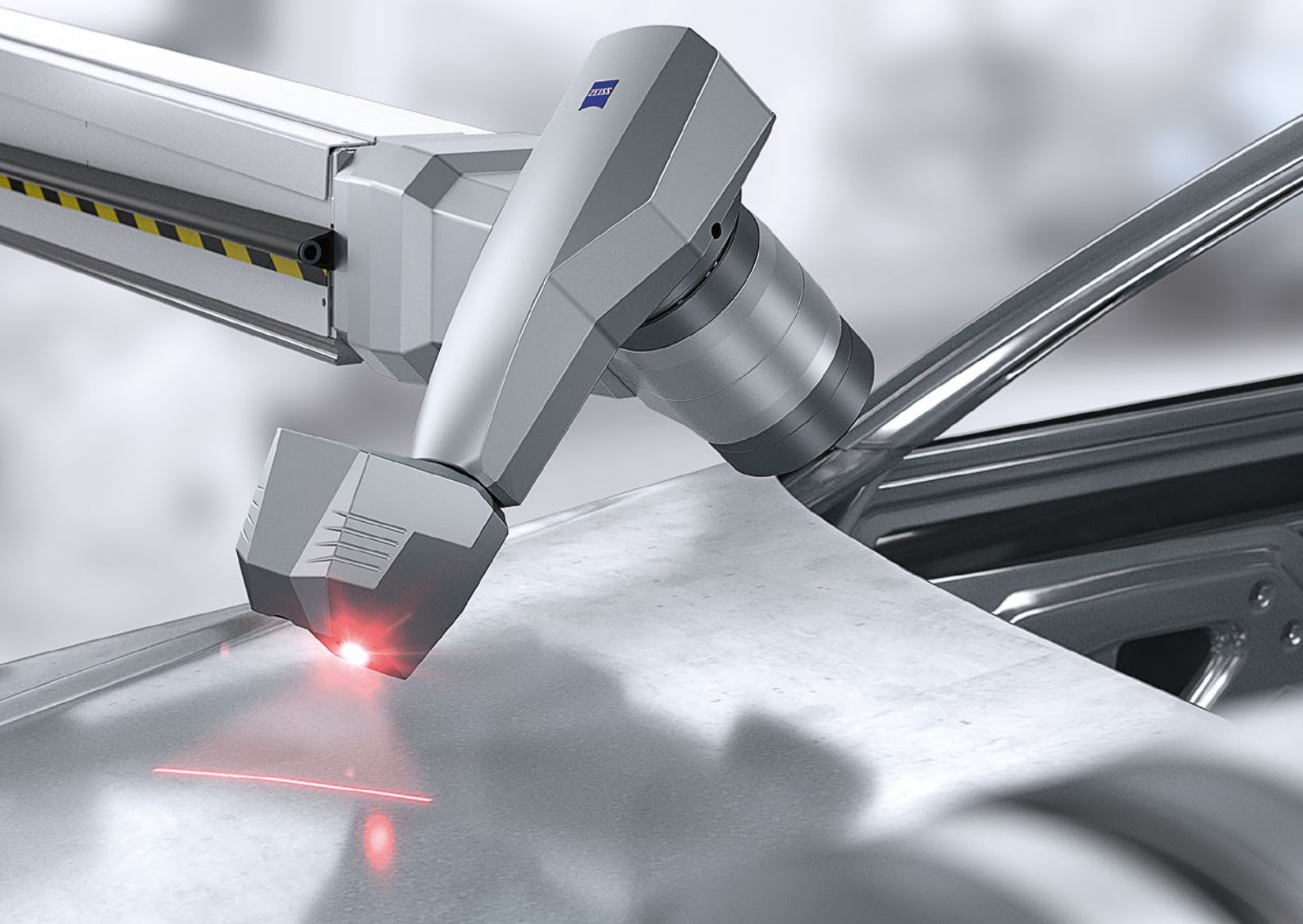

## ZEISS CALENO

ZEISS CALENO is a combination of CMM accuracy, collaborative system and an outstanding multi-sensor system with an automatic tool changer. Maximum versatility and highest performance capabilities ensure higher speed, acceleration and accuracy in the measuring room and near production.

With its combination of high-performance optical and tactile sensor, ZEISS CALENO ensures maximum productivity and precision. The optical system ZEISS EagleEye in ZEISS CALENO allows the reduction of measuring time for up to 85%\* with no compromise on quality and accuracy.

### Technical Specification

- Measuring Volume X/Y/Z from 70/18/30 to 70/30/30 (Duplex)
- Accuracy E0 in  $\mu\text{m}$  from  $27 + L/80 \leq 70$  (at 16 °C – 24 °C)  
 $18 + L/125 \leq 50$  (at 18 °C – 22 °C)



# ZEISS CALYPSO

## The direct path to meaningful results

Your software for coordinate measuring machines: ZEISS CALYPSO measures geometrical elements simply, quickly and reliably. Just click the desired features to configure inspection plans. Adjust the software to your demands: Due to numerous optional add-ons, the software also offers the right tools for special requirements.



### Technology-independent

ZEISS CALYPSO enables you to combine tactile, optical and multi-sensor coordinate measuring machines as well as roughness sensors by ZEISS in a single inspection plan.



### Intuitive and user-friendly

Create inspection plans with just a few simple clicks and without any programming skills. ZEISS CALYPSO is programmed directly at the workpiece or graphically at the CAD design.



### Location-independent

Optional add-ons allow you to create and store entire CNC inspection plans on a remote workstation.

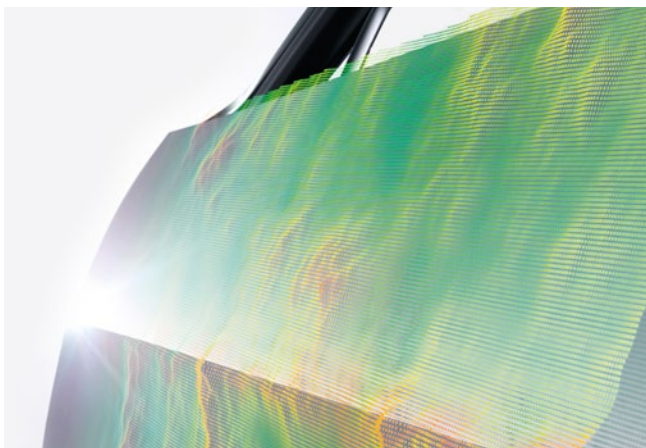

## ZEISS CALIGO

With its focus on freeform surfaces, ZEISS CALIGO is primarily aimed at users in car body construction. Measure and evaluate freeform surfaces and ruled geometries. The software supports measurements with horizontal arm devices and duplex systems.



## ZEISS GEAR PRO

The ZEISS GEAR PRO option for ZEISS CALYPSO enhances your coordinate measuring machines for gear measurement and detailed analysis of gears. GEAR PRO's analytical 3D gear model and graphics-supported input dialogs make measuring and evaluating data highly effective.

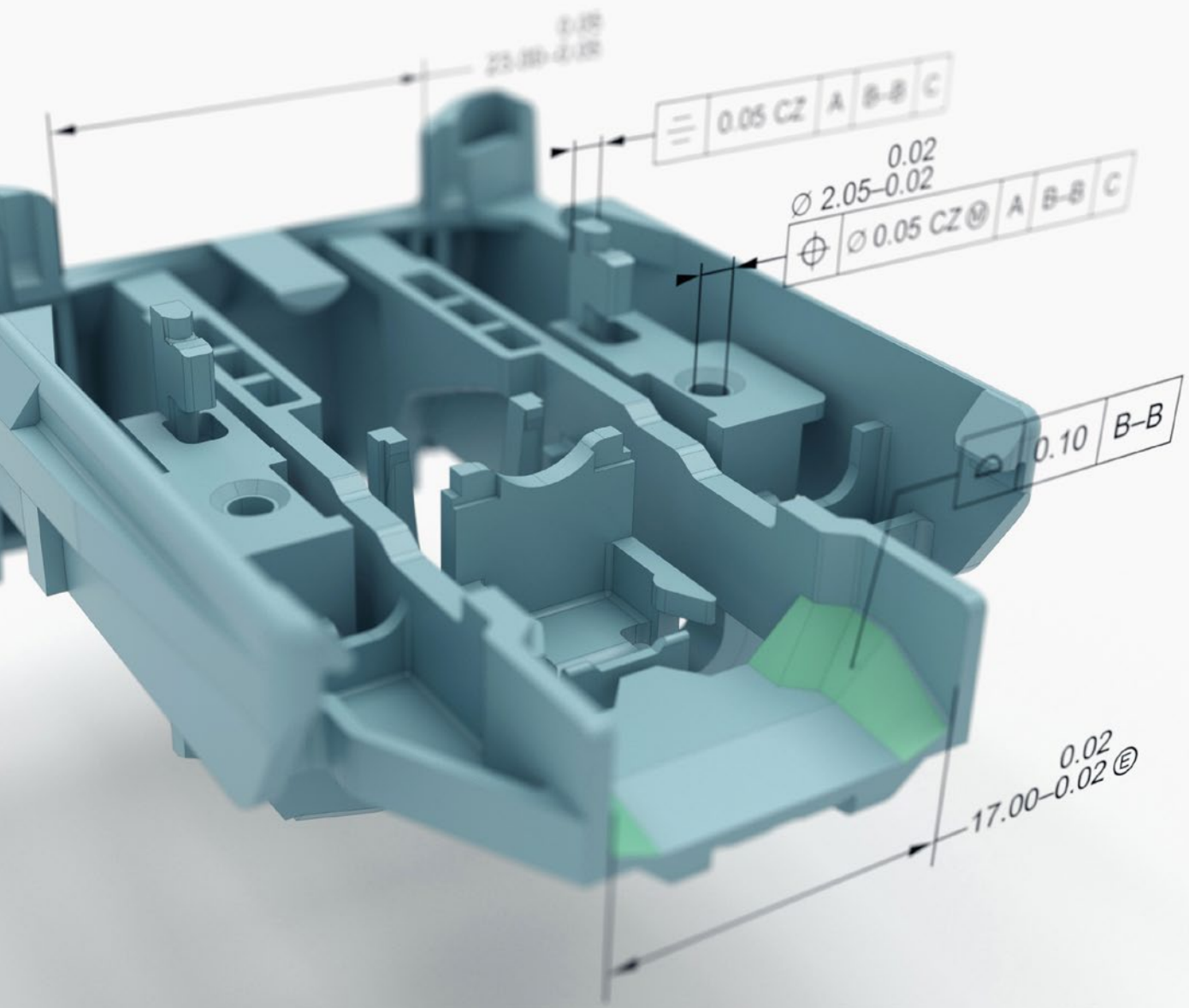

## ZEISS Smart Services Dashboard

With the ZEISS Smart Services Dashboard you keep track of the performance of your ZEISS CMMs. Benefit from greater machine availability, process safety and higher productivity. This allows you to unlock the full potential of your measuring solutions.

# Probes and Sensors

The CMMs are equipped with a variety of sensors to address different measurement needs. Whether optical or tactile, single-point or scanning, active or passive, each sensor type offers unique advantages and is tailored to specific applications, ensuring optimal performance across a wide range of industries.



## Tactile Probes

### VAST gold

The active measuring force control enables exact measuring results with complex long stylus systems and a high measuring throughput through navigator technology for optimal scanning performance.

#### Compatible ZEISS CMMs

- PRISMO, XENOS, MMZ



### VAST XT gold

The ZEISS VAST XT gold sensor is the compact version of the VAST gold active scanning sensor line from ZEISS. It provides the foundation for entry into the world of active scanning technology.

#### Compatible ZEISS CMMs

- SPECTRUM verity, CONTURA, MICURA, MMZ, PRISMO (standard and verity)



## VAST XTR gold

Thanks to the integrated rotary axis, the ZEISS VAST XTR gold probe always positions the stylus in the direction of the feature being measured, maneuvers effortlessly through gaps and thus gets wherever it is needed.

### Compatible ZEISS CMMs with RDS

- CONTURA, MICURA, PRISMO (not for PRISMO ultra), MMZ



## VAST XXT compact design

The VAST XXT compact design sensor significantly increases the available machine measuring volume and offers excellent workpiece accessibility.

### Compatible ZEISS CMMs with RDS

- SPECTRUM, CONTURA



## VAST XXT

There are a large number of measuring applications that can benefit from the flexibility of an articulating probe holder combined with scanning capability. ZEISS VAST XXT is ideal for such tasks.

### Compatible ZEISS CMMs with RDS

- SPECTRUM, CONTURA, PRISMO, MMZ

### Compatible ZEISS CMMs (fixed installation)

- SPECTRUM, CONTURA, DuraMax, O-INSPECT



## XDT

Thanks to a unique combination of technical features, the ZEISS XDT multipoint sensor enables a wide range of applications and delivers high precision in all probing directions.

### Compatible ZEISS CMMs with RDS

- CONTURA

### Compatible ZEISS CMMs (fixed installation)

- O-DETECT



## RST-P

This sensor is known for its fast and dynamic capture of measurement data through single-point probing, free from stylus bending and mechanical hysteresis.

### Compatible ZEISS CMMs

- CALENO





## Optical Probes

### EagleEye

The use of a completely new optical measurement technology saves up to 85% of the time required for measurements and eliminates time-consuming work steps. This leads to a significant improvement in the quality of car body components.

#### Compatible ZEISS CMMs

- CALENO



### LineScan

ZEISS LineScan is the tool of choice when capturing the entire surface of forms using point clouds is important – whether for a comparison with available nominal CAD data sets or for the creation of new CAD models.

#### Compatible ZEISS CMMs

- CONTURA, PRISMO, MMZ T, MMZ M, MMZ G



## LineScan One

ZEISS LineScan One is an optical laser triangulation sensor for capturing huge point clouds to compare nominal with actual geometry.

### Compatible ZEISS CMMs

- CONTURA, SPECTRUM



## DotScan

Chromatic white light sensors enable the non-contact capture of workpiece topography. They are generally used when sensitive, reflecting or low-contrast surfaces make the use of other optical sensors more difficult.

### Compatible ZEISS CMMs with RDS and optical fiber interface

- CONTURA, PRISMO, O-INSPECT (direct installation)
- MMZ T, MMZ M, MMZ G, all only on NSP request



# Roughness Sensor

Ensuring the quality of components, such as those in vehicle powertrains, requires precise evaluation of roughness and waviness. By implementing a roughness sensor, you can enhance measurement reliability while saving valuable time, all within a simplified and efficient workflow.

## ROTOS

With its modular design and three-axis rotation, ZEISS ROTOS delivers precision and exceptional flexibility for roughness measurements. The ability to easily change stylus arms extends the range of applications, providing maximum versatility.

### Compatible ZEISS CMMs

- PRISMO (no PRISMO ultra)





## **ZEISS Integration Series**

Unleash the full efficiency  
of your process



ZEISS Integration Series integrates your quality assurance, optimizes your processes and thus increases your productivity by selecting the right loading system or the ideal integration and automation solution for your measuring system. The broad spectrum of ZEISS solutions ranges from manual loading systems with ergonomic advantages to fully automated cells that increase the throughput of your quality assurance by maximizing machine utilization.

## Automation Interface

ZEISS Automation Interface enables easy automation through the whole IQS portfolio. It supports from easy manual QR-code scanning to fully automated loading processes via straightforward configuration. The modular software platform can be expanded, for example by upgrading from single-part to multi-part measurement.

### Compatible ZEISS CMMs

All CMMs



## FACS

For requirements exceeding the standard automation interface, the Flexible Automation & Connectivity System (FACS) offers a tailored software solution. FACS enables automation of recurring quality assurance tasks in complex processes, customized to meet your specific needs

### Compatible ZEISS CMMs

All CMMs

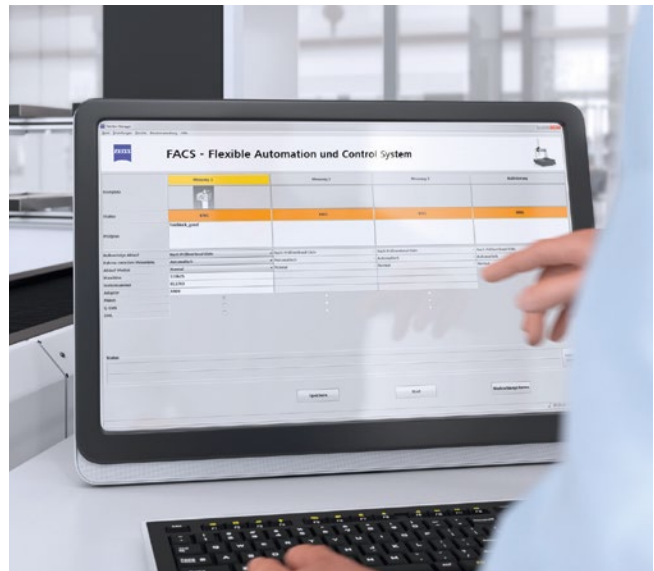

## ThermoStation

ZEISS ThermoStation protects measurement processes from extreme temperature changes and harsh production conditions. For instance, ZEISS CONTURA with its enclosed casing, can be used directly in production, ensuring accurate results. ThermoStation can seamlessly be connected with the ZEISS Integration Series loading systems.

### Compatible ZEISS CMMs

All CMMs



## ShuttleLoad

ZEISS ShuttleLoad automates loading and unloading of coordinate measuring machines, increasing throughput and reducing downtime. It supports unmanned shifts with automatic workpiece changeovers and is user-friendly, allowing untrained personnel to operate it easily.

### Compatible ZEISS CMMs

SPECTRUM, CONTURA,  
MICURA, PRISMO



## MultiLoad

MultiLoad enables simultaneous, automatic loading of up to four CMMs with workpieces. It features 16 storage locations for pallets, allowing unmanned shifts and maximizing throughput. Its tower design requires minimal space.

### Compatible ZEISS CMMs

SPECTRUM, CONTURA, MICURA,  
PRISMO, DuraMax, O-INSPECT

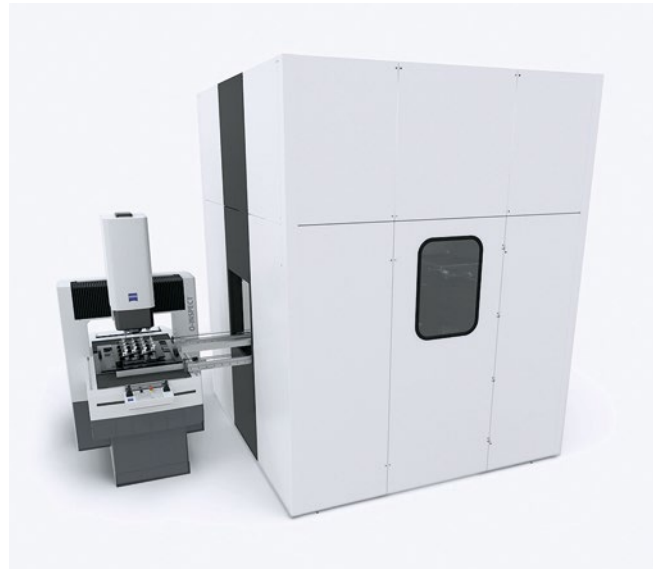

## DuplexSystem

ZEISS Duplex system boosts CMM utilization by enabling simultaneous clamping and unclamping during measurement. It features two pallet spaces for easy, ergonomic access. The optional Automation Kit automates pallet changes, allowing extended operation without an operator.

### Compatible ZEISS CMMs

DuraMax



## Manual loading systems

In addition to automated solutions, ZEISS also offers a portfolio of manual loading systems. These products can be used in the measuring room and in the production line. They can be flexibly combined with each other and increase the part throughput on your coordinate measuring machine.

### Compatible ZEISS CMMs

SPECTRUM, CONTURA,  
MICURA, PRISMO





## Optical 3D Metrology

Our industrial non-contact 3D measuring systems are designed to deliver precise, full-field 3D data in a minimal time. Utilizing advanced technologies such as structured blue light and laser triangulation, these systems produce high-resolution 3D models for detailed analysis and inspection. Their versatility and adaptability effectively address complex measurement and inspection challenges across diverse industries.

# 3D Scanning

## ZEISS ATOS 5

Developed for industrial use, ZEISS ATOS 5 delivers high-precision 3D data in a short measuring time. Especially for shiny and dark surfaces, fine structures and edges the sensor delivers full-field 3D scans, enabling comprehensive process and quality control.



## ZEISS ATOS 5X



Thanks to its powerful light source, ZEISS ATOS 5X enables the inspection of car bodies with maximum speed in automated applications. The integrated Laser Light Compressor generates ultra-bright light, thus enabling very short exposure times.



## ZEISS ATOS 5 for Airfoil

ZEISS ATOS 5 for Airfoil delivers precise data in a short time. It's high stability and optimized working distance make it ideal for small measurement areas. The full-field 3D measurement results enable reliable quality control, visualize hidden defects and thus accelerate the production of complex parts.



## ZEISS ATOS LRX



With a bright laser light source and a large measuring area of up to 4 m<sup>2</sup>, ZEISS ATOS LRX delivers precise, full-field data in short time. The sensor captures up to 2 x 12 million coordinate points with just one scan.



## ZEISS ATOS Compact Scan

The portable and lightweight 3D scanner ZEISS ATOS Compact Scan is designed for a wide range of applications. With different measuring volumes the system delivers high-resolution results whether scanning small or large parts.





## #HandsOnMetrology

#HandsOnMetrology is the new go-to for everything you want to know about 3D scanning. From step-by-step setup instructions to more advanced tutorials and expert hacks: This platform is made for learning. For getting inspired. And for finding the support you need to deliver 3D scanning excellence. This platform is made for you.

### ZEISS T-SCAN hawk 2

The hand-held laser scanner captures data wherever you need. With its flexible design it adapts to your unique measuring task. Inspect finest details as well as large objects up to multiple meters. Powerful lasers ensure metrology-grade precision in a seamless workflow.



### ZEISS ScanPort

ZEISS ScanPort easily captures 3 axes of objects with just one click. The mobile and flexible semi-automated solution delivers metrology-grade data of small to medium-sized parts. It is suited for various applications, like casting, additive manufacturing or plastics.





## ZEISS ATOS Q

Designed as a flexible 3D scanner for complex measurement and inspection tasks, ATOS Q meets high metrological demands for many industries. The Triple Scan Principle and Blue Light Equalizer enable maximum precision, even on challenging surfaces.



## ZEISS GOM Scan 1

The lightweight solution allows you to capture 3D data intuitively. Easy to operate, GOM Scan 1 is the specialist for simple and fast measurements of small to medium-sized parts – even in confined spaces.

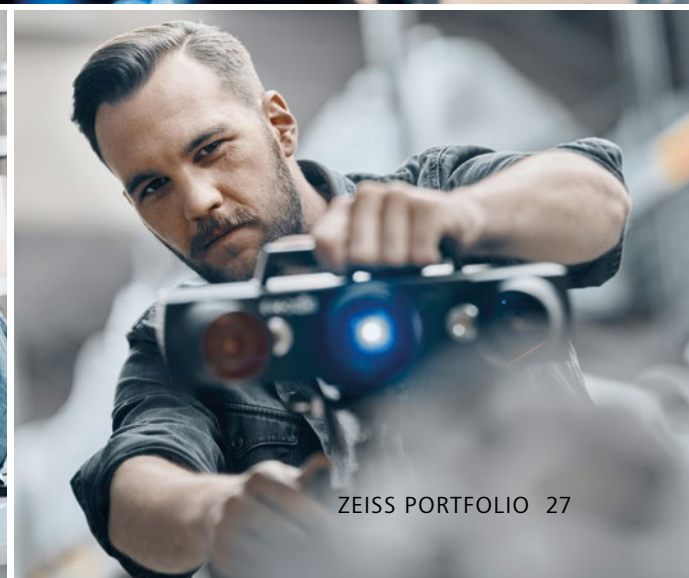

# ZEISS CORRELATE

Analyze movements, displacements and strains three-dimensionally

- ✓ Intuitive to use
- ✓ Fast analyses
- ✓ Individual functions with apps

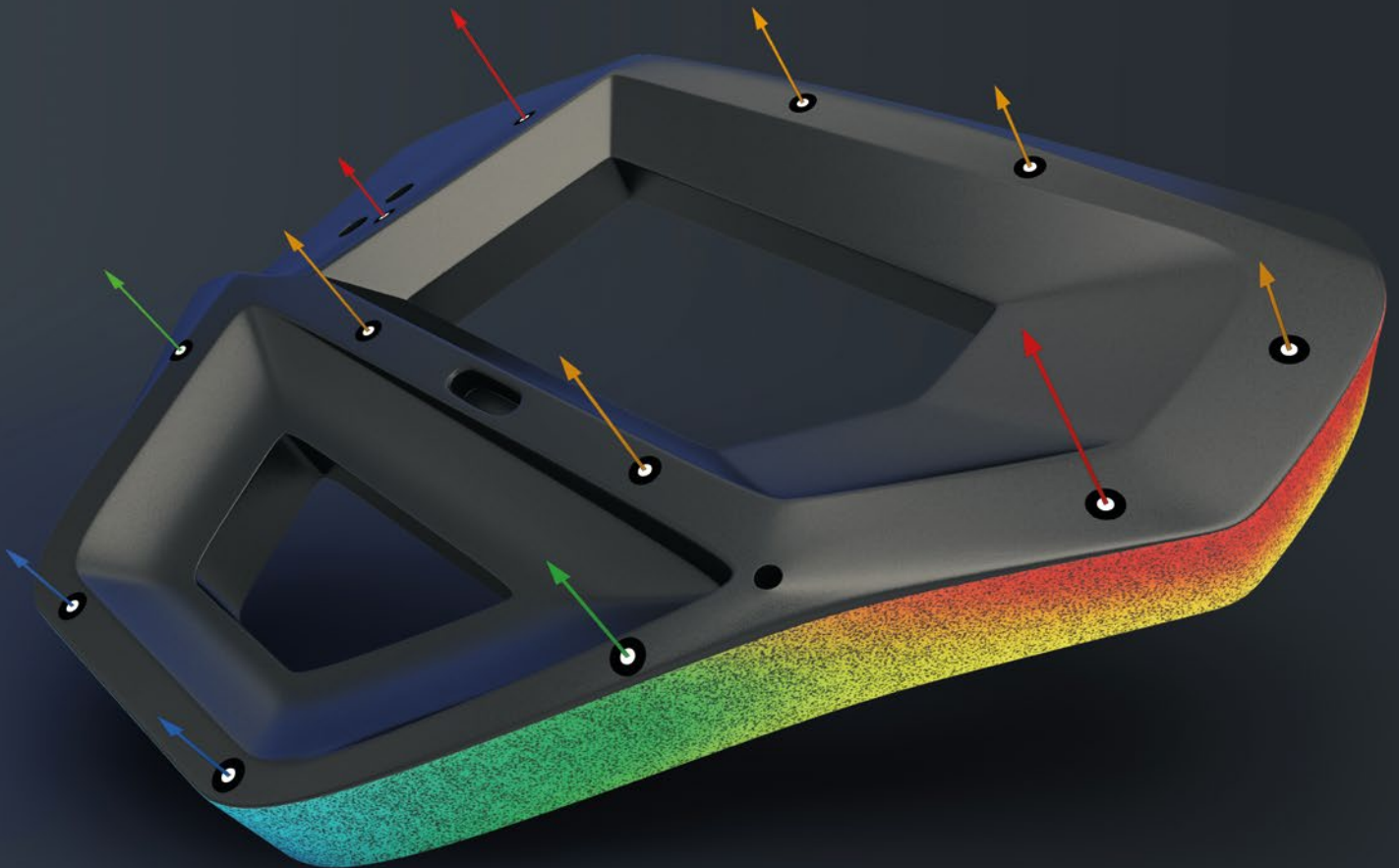

Turn videos into meaningful measurement data. With ZEISS CORRELATE, you can analyze dynamic processes such as displacements, rotations or angle changes. Intuitive to use and equipped with practical functions, the software optimally supports you in your 3D testing applications. Use digital image correlation and point tracking algorithms for sub-pixel accurate measurement of 3D coordinates and track them over time.

# 3D Photogrammetry

## ZEISS PONTOS Live

Designed for the production environment, the ZEISS PONTOS Live tracking system is used for the live positioning of parts. Equipped with the Touch Probe, the system enables the combination of optical and tactile measurements.



## ZEISS TRITOP

The digital photogrammetry camera ZEISS TRITOP captures 3D coordinates of individual measuring points on objects and components. The portable system is specially designed for harsh measuring environments directly in production, in a climate chamber or offshore.



# 3D Testing

The ZEISS 3D testing portfolio includes sensors for dynamic or static acquisition of 3D coordinates, displacements, and surface strains. Using photogrammetric methods like triangulation and bundle block adjustment, the systems deliver precise 3D coordinates for full-field and point-based analyses of deformation.

## ZEISS ARAMIS 3D Camera

ZEISS ARAMIS 3D Camera is a high-resolution optical 3D measuring system for performing full-field and point-based measurements. With high stability, process reliability and ease of use, the system is suitable for high-end applications in industrial environments and offers suitable configurations for a wide range of testing tasks.



## ZEISS ARAMIS Adjustable

ZEISS ARAMIS Adjustable provides precise 2D and 3D coordinates for the analysis of statically or dynamically stressed components and materials. The individually expandable system offers suitable configurations for a wide range of inspection tasks and meets the highest metrological requirements based on digital image correlation.



## ZEISS ARGUS

ZEISS ARGUS supports the optimization of sheet metal forming processes through reliable and precise measurements of surface strains on components. The system uses photogrammetry principles to determine a three-dimensional image of a component in order to evaluate its forming state and validate simulations.





## Automated Solutions

Automated quality assurance processes are essential for ensuring economic success in modern production environments. By identifying errors early and enabling timely corrections, these systems help maintain efficiency and product quality. ZEISS provides a versatile portfolio of solutions for automated quality control, designed to meet the specific needs of manufacturing processes for components of all sizes, from small parts to large assemblies.

## ZEISS ABIS III

ZEISS ABIS III combines high-speed inspection with a reliable detection of all relevant surface defects such as dents, bulges, sink marks, ripples, neckings, cracks and now also scratches and pressure marks. The system inspects both moving and stationary parts reproducibly and highly precise during live production and within the cycle time. Moreover, it is not only suited for in-line but also for at-line use in production environment.



#HandsOnMetrology

## ZEISS ScanCobot

ZEISS ScanCobot is a mobile measuring station with a collaborative robot, motorized rotation table and powerful software. The system is especially suited for the efficient quality control of small and medium-sized parts made of plastic, metal or cast iron. It can be used during the pre-production phase, such as design and prototyping, as well as during market launch.



## ZEISS ScanBox Series 4

ZEISS ScanBox Series 4 is an optical 3D measuring machine for the inspection and digitization of small and complex parts up to 500 mm in size. The compact and mobile system is ready for use thanks to the plug & play concept and can be easily repositioned if required.



## ZEISS ScanBox Series 4 RC

ZEISS ScanBox Series 4 RC (Remote Control) is an optical 3D measuring machine with a motorized sliding door. With a robot or a customized loading system, parts can automatically be loaded into ZEISS ScanBox Series 4 RC and placed on the rotation table module. The elimination of manual individual placement significantly reduces the inspection time required and therefore ensures a higher throughput in quality assurance.



## ZEISS ScanBox 4105 for eMotors

ZEISS ScanBox 4105 for eMotors is specialized in the very fast and precise inspection and digitization of hairpins and stators. Both, complete stators including hairpins and individual or multiple hairpins can be inspected fully automated within a very short time. The captured 3D measurement data are visualized and analyzed in the powerful inspection software ZEISS INSPECT. This model is also optionally available as RC version.





## ZEISS ScanBox Series 5

ZEISS ScanBox Series 5 is an all-in solution for automated inspection and digitization of complex parts. The series consists of three models and offers many options for customizing to individual needs. The individual components are identical and therefore offer perfect possibilities for upgrading to different layouts. The maximum load of the rotation table module is 2000 kg.



## ZEISS ScanBox Series 5 RC

ZEISS ScanBox Series 5 RC (Remote Control) is an optical measuring machine with a motorized sliding door. With a robot or a customized loading system, parts can automatically be loaded into ZEISS ScanBox Series 5 RC and placed on the rotation table module. As the user does not have to place the individual parts, the inspection time required for quality assurance is significantly shorter than before.

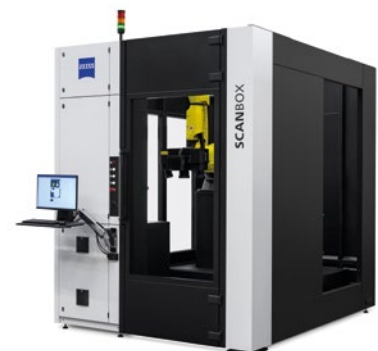



## ZEISS ScanBox Series 6

In the production environment, it is important to identify, analyze and eliminate quality problems as fast as possible. For that, as many parts as possible must be completely checked in the shortest amount of time to be able to initiate targeted corrective measures at short notice and to minimize scrap. This challenges can be mastered with ZEISS ScanBox Series 6.



## ZEISS ScanBox Series 7

Automated 3D measurement technology for car manufacturing, try-out toolmaking and press shops: ZEISS ScanBox Series 7 digitizes and inspects large and heavy parts, such as automobile side panels and attached parts of up to 10 meters in size. In addition, welded assemblies for transportation, mechanical engineering and aircraft construction can be measured.



## ZEISS ScanBox Series 8

This 3D measuring machine is designed for something big: With ZEISS ScanBox Series 8, complete vehicles are digitized at high speed, both from the outside and the inside. The modular measuring cell has established itself among OEMs as a complete solution for analyses in Meisterbock and Cubing, the inspection of finished vehicles, and for quality assurance in car body manufacturing



# ZEISS INSPECT OPTICAL 3D

## The standard for your 3D surface inspection

Take your inspection tasks to a whole new level. From full-field data acquisition and mesh processing to trend analyses and digital assembly, ZEISS INSPECT supports you with a consistent workflow and user-centric operation. Easily create digital twins for a comprehensive and detailed analysis.

- ✓ Powerful metrology functions – intuitive and fast
- ✓ Automated programming and inspection made easy
- ✓ Streamlined workflow for ZEISS optical measuring systems

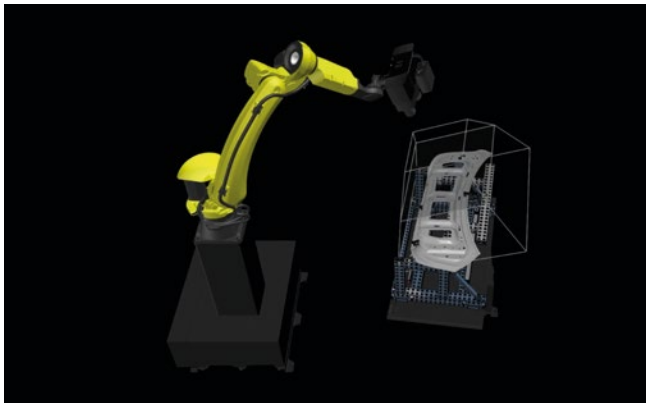

### Virtual Measuring Room (VMR)

The Virtual Measuring Room (VMR) app enables automatic measuring procedures and represents the real environment in a virtual simulation. Optimize your measurement planning and automate robot programming and reporting processes without a teach pendant. No special robot skills required.

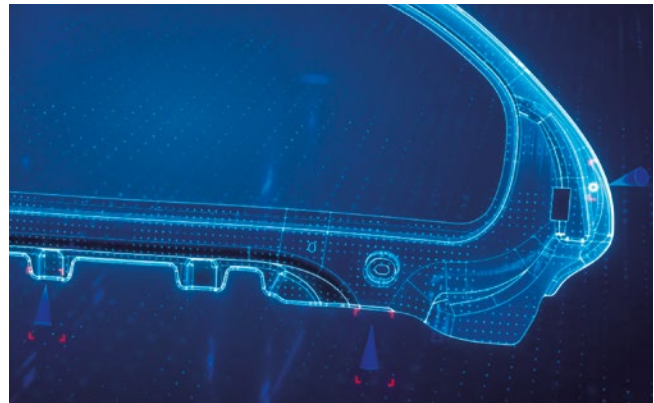

### Virtual Clamping

Measure clamping conditions without any fixtures. The Virtual Clamping app simulates the clamping of parts and allows you to compute the clamped state using the data of the real part in free state. This step is fully integrated into the workflow of ZEISS INSPECT.

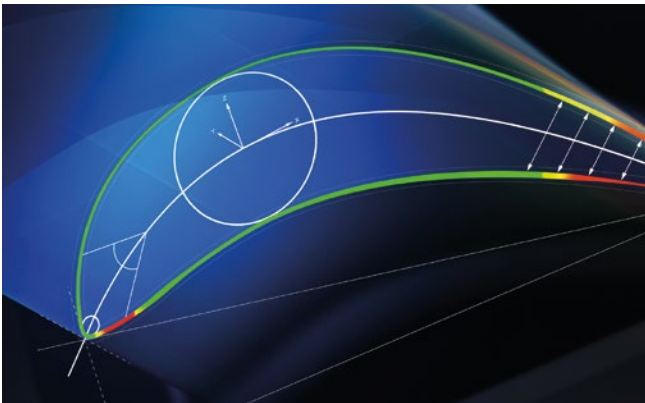
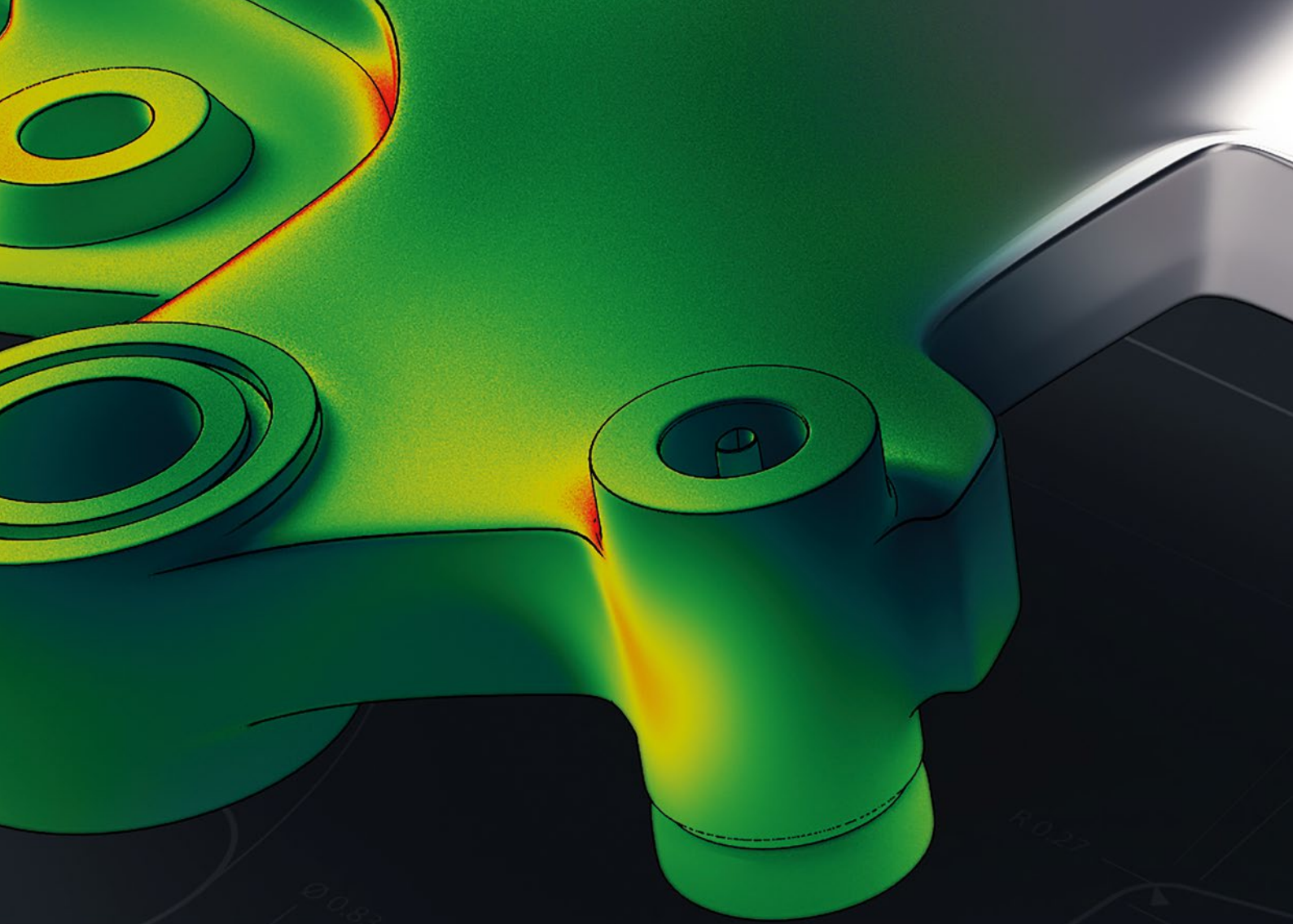

## **Airfoil Inspection**

With specific analysis functions and useful 2D and 3D evaluation features for turbines and blade wheels, Airfoil Inspection sets new standards in the visualization and evaluation of measurement data.

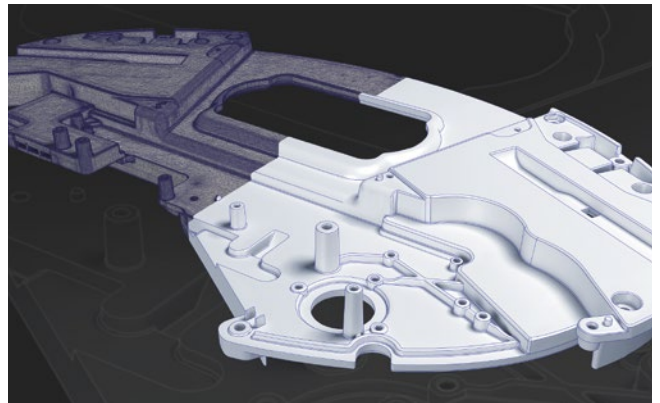

## **ZEISS REVERSE ENGINEERING**

From 3D scan to CAD model: ZEISS REVERSE ENGINEERING offers you a simple software solution for reverse engineering. In just a few guided steps, a highly accurate CAD model is created. With the additional tool correction option, you save iteration loops in the correction process.



## 2D X-Ray

The robust and reliable 2D X-ray solutions of the ZEISS BOSELLO product family are especially designed for fast defect detection in tough production environments. With ZEISS BOSELLO, automated or manual non-destructive 2D X-ray inspection as well as high throughput and productivity are guaranteed – thanks to quick loading and unloading, fast cycle times and flexible applications directly in-line or near production.

## ZEISS BOSELLO MAX

ZEISS BOSELLO MAX is the customizable 2D X-Ray solution for your defect detection needs in the production environment. Our proprietary image processing algorithms and the computed tomography enhancement allow the detection and complete analysis of various castings. The reliable 2D X-Ray technology ensures sharp results and quality control for a large range of workpieces – even in the toughest conditions. The system is CT-ready and enables the creation of 3D models based on a series of images.



## ZEISS BOSELLO HEX

ZEISS BOSELLO HEX enables fast inspections of small to mid-sized castings – for everyone. With this system you can flexibly configure your optimum 2D X-ray solution that fits your needs and your budget. The unique image processing algorithms of our software guarantee best 2D image quality. The system is CT-ready and enables the creation of 3D models based on a series of images.



## ZEISS OMNIA GC 220-180

The system addresses the need for quality assurance of large-scale castings, offering a future-proof solution for defect detection in aluminium components. With an inspection volume of 2200x1800x900 mm and a focus on automation, ZEISS OMNIA GC 220-180 enables 2D X-ray imaging in short cycle times and optimizes the entire production process across industries – whether in in-line or at-line operation.



## ZEISS BOSELLO OMNIA

With its robust design and customizable setup, ZEISS BOSELLO OMNIA is the ideal 2D X-ray system for harsh production environments. The Automatic Defect Recognition software in combination with automated 100% in-line inspection guarantees fast and reliable defect detection for your quality assurance. Moreover, multi-shift operation and a clever pallet loading system for parallel changing and loading ensure high throughput for the inspection of various types of castings.



## ZEISS BOSELLO WRE thunder

Enabling rapid inspection of light alloy wheels within the production cycle, ZEISS BOSELLO WRE thunder is a high-speed, in-line system designed for 2D X-ray defect detection. The system ensures a reliable inspection of all produced wheels, accurately identifying and evaluating critical defects in accordance with specified requirements.





## **3D X-Ray**

The industrial computed tomography systems from ZEISS enable you to perform advanced metrology and inspection tasks for a huge variety of applications. Whether plastic, metal, or multi-material, 3D X-ray systems inspect your parts quickly and reliably. They give you perfect insight and provide non-destructive testing of both, external and internal structures.

## ZEISS METROTOM 1500

With ZEISS METROTOM 1500, you get advanced and flexible CT technology – reliably detecting flaws by capturing and measuring defects beneath the surface. It delivers fast and high-resolution images for both small and large parts –and everything in between. The hardware module ZEISS scatterControl ensures unchallenged image quality and makes it an ideal system for inspecting multi-material parts.



## ZEISS METROTOM 800 320 kV

ZEISS METROTOM 800 320 kV is the perfect system for penetrating, inspecting and accurately measuring high-density parts non-destructively. It features a high-kV microfocus tube with up to 500 W power, a large-area X-ray detector and a precise, metrology-grade positioning system. This provides class-leading versatility that can be used across a wide range of applications while delivering exceptional image quality thanks to its compatibility with ZEISS scatterControl.



#HandsOnMetrology

## ZEISS METROTOM 1

Powered with computed tomography technology, you can scan non-destructively and look inside your part. Measure, analyze and inspect hidden defects and inner structures of a wide range of plastic parts. With ZEISS METROTOM 1 you can also easily decrease your scan time by capturing data of multiple parts at once.





## ZEISS METROTOM 800 225 kV

ZEISS METROTOM 800 225 kV is appreciated for its flexibility. From small plastic or metal parts up to medium-sized mixed material parts like connectors, the system can handle it all. The same flexibility applies to various applications, including dimensional inspections, defect analysis, and assembly control, to name a few.



## ZEISS METROTOM 800 130 kV

ZEISS METROTOM 800 130 kV is equipped with components to achieve highest possible accuracies. This makes the system the perfect choice for challenging applications, such as the metrological inspection of small to mid-sized plastic components with very tight tolerances. The system is distinguished by its low maintenance requirements, which help keep operating costs to a minimum.



## ZEISS METROTOM 6 scout

ZEISS METROTOM 6 scout digitizes complex parts, including internal geometries, at an exceptional level of detail. The result is a complete 3D volume for GD&T analysis, nominal-actual comparisons or defect analyses. The CT metrology system is an excellent choice for digitizing small plastic parts.



## ZEISS VoluMax 9 titan

ZEISS VoluMax 9 titan combines powerful technology with maximum ease of use. Being equipped with a tube voltage of 450 kV and power of 1,500 W, the CT system offers remarkable penetration strength and reliably detects defects in both high-density parts and complex multi-material assemblies. Its compact design optimizes the use of available space.



## ZEISS INSPECT X-Ray

Powerful inspection on  
your x-ray data

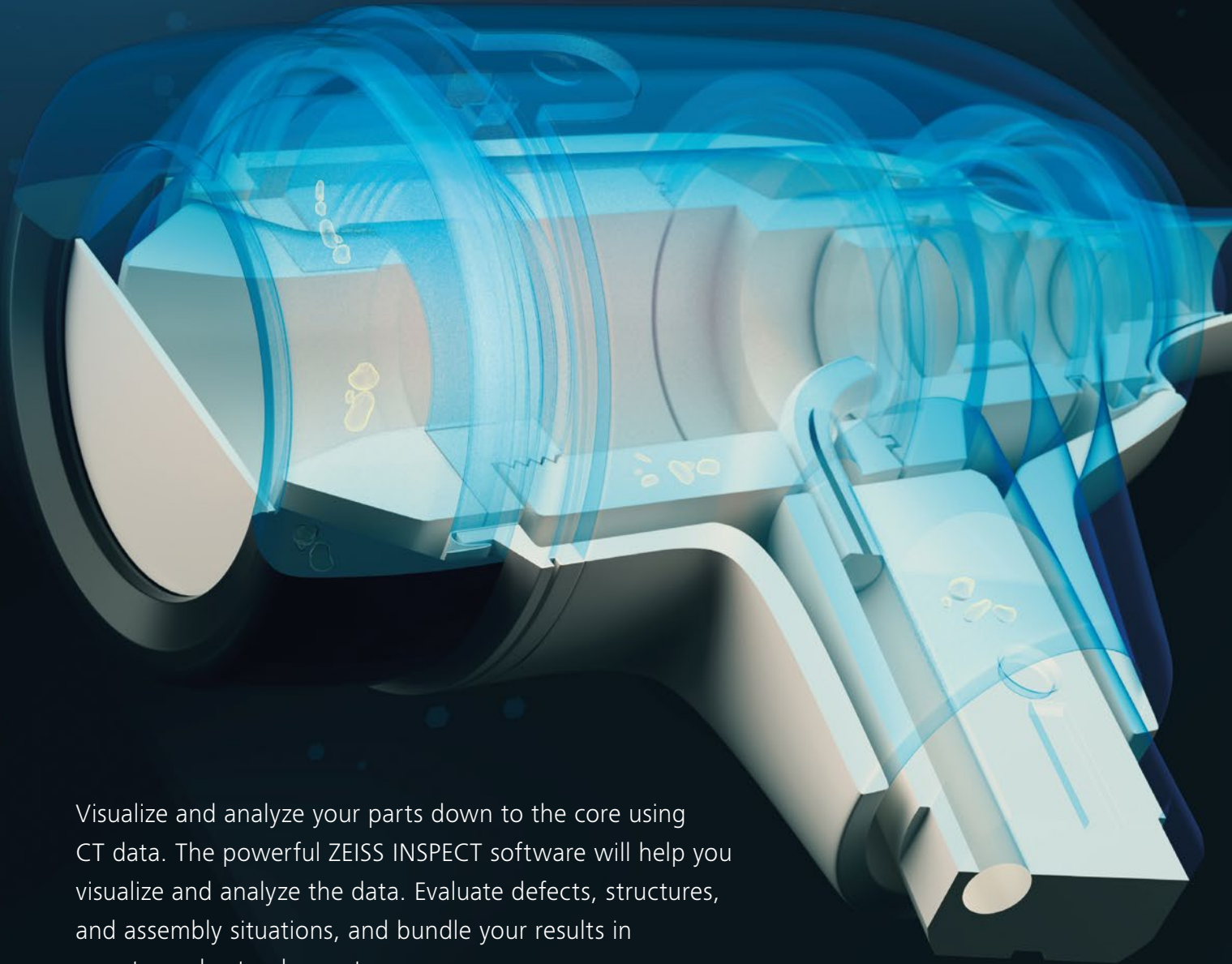

Visualize and analyze your parts down to the core using CT data. The powerful ZEISS INSPECT software will help you visualize and analyze the data. Evaluate defects, structures, and assembly situations, and bundle your results in easy-to-understand reports.

- ✓ Integrated solution: consistent and intuitive workflow
- ✓ Automated inspection of multiple parts
- ✓ Increased efficiency with AI-based tools

# ZADD SEGMENTATION

The app ZADD Segmentation transforms the analysis of 3D X-ray data with AI-based automated inspection. Seamlessly integrated into your ZEISS INSPECT X-Ray workflow, it detects small and fuzzy defects in components reliably and quickly even on poor image quality. Leverage pre-trained or customized AI models – for maximum efficiency and reliability.

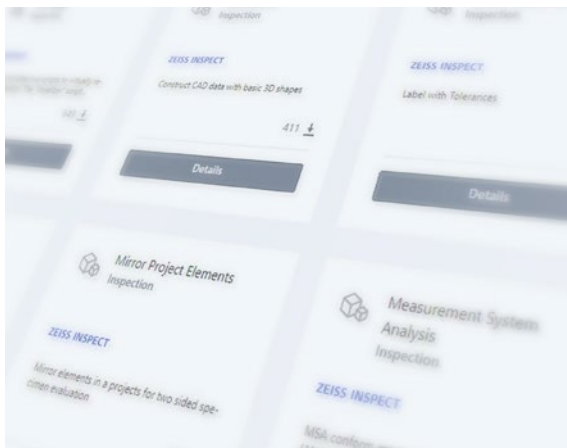

## ZEISS Quality Software Store

Do you need more functions? Customize your software with optional apps. Get your software and apps in the ZEISS Quality Software Store. Easily access the 30 day trial and free version of our software there.

[software-store.zeiss.com](https://software-store.zeiss.com)





# Stereo and Zoom Microscopes

The closer you look, the more you see. ZEISS stereo and zoom microscopes are easy to operate, even for inexperienced users, providing you with information on color, morphology, structure, texture and dimensions. Whether in production environments or in the quality lab, fast imaging helps you to make informed decisions and keep quality at the highest level.

## ZEISS Axio Zoom.V16

ZEISS Axio Zoom.V16 is the high resolution, apochromatically corrected on-axis zoom microscope from ZEISS. With a magnification range of 16:1, you can zoom from a large overview (33 mm) down to the smallest detail (0.7  $\mu\text{m}$ ). This is particularly beneficial for automated stitching of large tile images and makes ZEISS Axio Zoom.V16 the preferred solution for particle analysis, technical cleanliness and high-resolution applications.



## ZEISS SteREO Discovery

Inspect large components like PCBs with exceptional depth perception across the entire 20:1 zoom range. The motorized zoom with an electronically-generated zoom curve lets you take precise control of freely-selectable magnification positions, giving you the advantage of reproducing your image scale with high accuracy.



## ZEISS Stemi 508

ZEISS Stemi 508 is your robust multi-purpose inspection tool for daily work in quality control. Observe and document your components with outstanding image contrast and color fidelity. Various stand and illumination options help you to create an inspection environment that supports inspection efficiency and the ergonomic needs.





# Digital Microscopes

Go digital to become smarter, faster and have confidence in your data. Simplify and speed up imaging and documentation tasks while improving throughput.

## ZEISS Smartzoom 100

The ZEISS Smartzoom 100 digital microscope for optical inspection delivers 4K live images at 60 FPS with automatic focus adjustment. With a 370 mm working depth, vibration reduction, and magnetic lenses, it excels in quality assurance, from incoming goods inspection to lab use. Its flexible controls and all-in-one design make it ready to use right away.



## ZEISS Smartzoom 5

ZEISS Smartzoom 5 digital microscope assists operators with consistent execution of recurring, routine imaging and measurement tasks with guided, easy to set up, automated workflows. Intuitive GUI and controls make topography and large area imaging easy.



## ZEISS Visioner 1

ZEISS Visioner 1 revolutionizes the world of optical inspection and documentation. Driven by the unique Micro-mirror Array Lens System (MALST<sup>™</sup> technology), it enables for the first time, up to 100× more depth of field than traditional inspection microscopes.



# Laser Scanning Microscope

ZEISS confocal systems offer sub-micron resolution for the most demanding of non-contact surface measurement tasks, such as roughness or topography analyses of sensitive materials.

## ZEISS LSM 900 for Materials

ZEISS LSM 900 for Materials is the one instrument you will need for materials research and analysis to characterize 3D microstructures and surfaces. When you upgrade your ZEISS Axio Imager 2 upright light microscope or ZEISS Axio Observer 7 inverted microscope with ZEISS LSM 900 for Materials, you will be combining all essential light microscopy contrasting methods for materials with high-precision topography – on a single instrument.



## Wide Field Microscopes

ZEISS is renowned for its expertise in developing light microscopes with exceptional optical performance for materials investigation. Each microscope in the portfolio is tailored to specific applications, ranging from routine metallography to advanced material and failure analysis.



## ZEISS Axio Observer

Take advantage of the inverted microscope design to efficiently investigate multiple samples, or components that would ordinarily be restricted when it comes to microscopic analysis due to size. There's no need to refocus, even when changing magnification or switching samples. ZEISS Axio Observer combines the proven quality of ZEISS optics with automated components to give you reliable, reproducible results.



## ZEISS Axiovert

Produce high-quality images of large and heavy samples effortlessly with ZEISS Axiovert. Let the system take care of selecting the settings. You don't even need a PC to view and document images – just connect with a monitor and save directly to a USB device. The motorized Z-focus and motorized XY stage make Axiovert 7 your candidate for even more workflow automation and advanced imaging.



## ZEISS Axio Imager

ZEISS Axio Imager 2 is your system platform tailored to demanding materials analysis tasks, development of new materials as well as routine quality control and particle analysis. Obtain reproducible results and high productivity by automating your workflows, with up to 7500x magnification\* for the most challenging analysis requirements. ZEISS Axio Imager 2 offers a high degree of adaptability in line with your future requirements as well as being central to a multi-modal workflow.

\*on screen magnification based on a 26" monitor and specific camera / objective configuration



## ZEISS Axioscope

Choose ZEISS Axioscope if your inspection tasks place high demands on usability, reproducibility and automation – and you also need advanced options for research-grade materials analysis. ZEISS Axioscope 7, the motorized model in the product family, enables you to automate much of your work process and opens many opportunities for advanced imaging. Benefit from higher productivity, repeatable processes based on predefined parameters and better comparability of results.



## ZEISS Axiolab

ZEISS Axiolab 5 is the right choice if your routine metallography applications place high demands on ergonomic operation and efficient digital documentation. Since the Smart Microscopy concept does not require additional imaging software or even a computer, ZEISS Axiolab 5 is also the first choice from an economic point of view.





## Scanning Electron Microscopes

ZEISS scanning electron microscopes (SEM) excel when the resolution or contrast limits of light microscopy are reached, yet further insights are needed. Their high-resolution imaging and material analytics capabilities make them invaluable for industrial quality control, failure analysis, and research applications.

## ZEISS EVO

ZEISS EVO offers an operational concept that appeals not only to experienced users, but also to engineers who are not SEM experts. It delivers high-quality data, especially for non-conductive parts and challenging material samples. In combination with the standards-compliant SEM particle analysis solution ZEISS SmartPI, EVO allows particle classification based on their size, shape and elemental composition.



## ZEISS Sigma

ZEISS Sigma 360 delivers excellence in price and performance while Sigma 560's best-in-class EDS geometry delivers superb analytical performance. Extract topography, composition and crystallographic information to characterize all your samples. Choose from a variety of detector options to tailor ZEISS Sigma precisely to your applications: you can image particles, surfaces, nanostructures, thin films, coatings and layers.



## ZEISS GeminiSEM

ZEISS GeminiSEM stands for effortless imaging with sub-nanometer resolution and high detection efficiency. Analyze failures in semiconductor materials, examine the microstructure of high-performance steel, characterize polymers, understand the aging process of batteries – ZEISS GeminiSEM will support the most challenging applications, especially when you have to characterize materials which require low voltages.



## ZEISS Crossbeam

Combine imaging and analytical performance of a field emission scanning electron microscope with the processing ability of a focused ion beam (FIB). Prepare high quality samples, like TEM lamellae, using the FIB's low voltage performance, and characterize your samples comprehensively in 3D. Benefit from up to 40 % faster material removal by the introduction of intelligent FIB milling strategies or enable fastest material removal rates with a fs-laser. Enjoy best 3D resolution and leading isotropic voxel size in FIB-SEM tomography.



## X-Ray Microscopes

X-ray microscopes enable non-destructive characterization of material properties and behaviors. They provide three-dimensional visualization of microstructures and structural details with high contrast and submicron resolution imaging, even for larger samples.



## ZEISS XRM Versa

ZEISS Versa 3D X-ray microscopes (XRM) provide superior 3D image quality and data for a wide range of materials and working environments. The system features dual-stage magnification based on synchrotron-caliber optics and revolutionary RaaD™ (Resolution at a Distance) technology for high resolution even at large working distances. Non-destructive imaging preserves and extends the use of your valuable sample, enabling 4D and in situ studies. The Unique Advanced Reconstruction Toolbox (ART) further enhances results and usability with market leading AI based image quality and throughput improvements.



## ZEISS XRM Context

ZEISS XRM Context® micro-computed tomography (microCT) is an easy-to-use system for analysis of all types of samples. A high-array detector enables high-resolution analysis of fine details even with relatively large imaging volumes. The system features a large field of view, rapid sample mounting and alignment, streamlined acquisition workflow and fast exposure and data reconstruction times.



## ZEISS XRM Ultra

Synchrotron X-ray nanotomography enables non-destructive 3D imaging at the nanoscale but you have to apply for very limited beamtime. Imagine if you had synchrotron capabilities in your own lab. With the ZEISS XRM Ultra you have 3D non-destructive X-ray microscopes at hand that deliver nano-scaled resolution with synchrotron-like quality.



## ZEISS XRM CrystalCT

ZEISS XRM CrystalCT® platform uniquely augments this powerful imaging technique with the ability to reveal crystallographic grain microstructures, transforming the way polycrystalline materials (such as metals, additive manufacturing, ceramics and others) can be studied, leading to newer and deeper insights for your materials research.



## ZEISS ZEN core

### The Platform for Microscopy in Industry

All-in-one software for imaging, analysis, and data management. Integrates light and electron microscopy into efficient workflows with automation and precise analysis.

- ✓ Smooth operation: Single interface for imaging, EDX control, measurements, and AI analysis
- ✓ Flexible expansion: Modular design with optional toolkits
- ✓ Boosted productivity: AI-powered automated segmentation and precise data analysis



## ZEISS arivis Cloud

### Training AI Models for Image Analysis

Available as a standalone solution or used alongside the complete ZEISS microscopy ecosystem, such as ZEN core, arivis Pro, and arivis Hub. ZEISS arivis Cloud makes it easy to train your own deep learning models in the cloud.

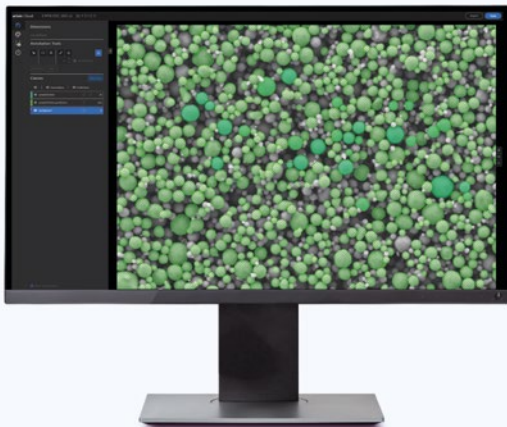

- ✓ Cloud AI: Train models with no coding
- ✓ Flexible use: Run in cloud or export to ZEISS ecosystem
- ✓ Collaboration: Access and share anywhere



## **ZEISS ART and ZEN navx** AI-powered Technologies for ZEISS X-ray Microscopes

ZEISS ZEN navx is the intuitive guidance and control software for XRM systems, enabling efficient, reproducible workflows. The ZEISS Advanced Reconstruction Toolbox (ART) is an AI-powered tool that works with ZEN navx to enhance image quality and speed up analysis, delivering up to 10x higher throughput.

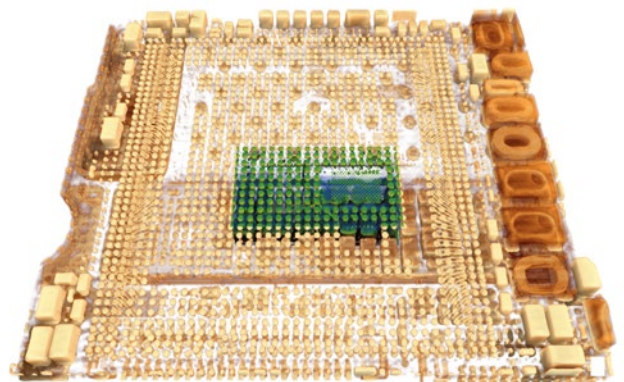

- ✓ Enhanced resolution, contrast, image quality, and improved artifact reduction
- ✓ Higher throughput and simplified operation
- ✓ Analysis of various sample types, sizes, and shape



# ZEISS CONNECTED QUALITY

One Metrology Hub.  
Insights. Collaboration. Productivity.

With ZEISS CONNECTED QUALITY we facilitate traceable, secure and global quality processes, offer access to system health & utilization data and contribute to centrally managed global quality operations. It is your central collaboration platform for enabling global metrology operations.



## ZEISS CONNECTED Inspection

With ZEISS CONNECTED Inspection you can share your measurement data and work collaboratively on metrology projects. It is your solution for versioning, approving and archiving of inspection plans and results. Centralize your inspection planning and work together in one place.



## ZEISS CONNECTED Telemetry Data

With ZEISS CONNECTED Telemetry Data, you can seamlessly integrate data of your measuring system into your preferred platform, such as ERP and MES, enabling new possibilities for your specific application. By using a standardized semantic data model (OPC UA Companion Specification), data is consistently available and accessible in any system.

# ZEISS PiWeb

Transform quality data into meaningful results

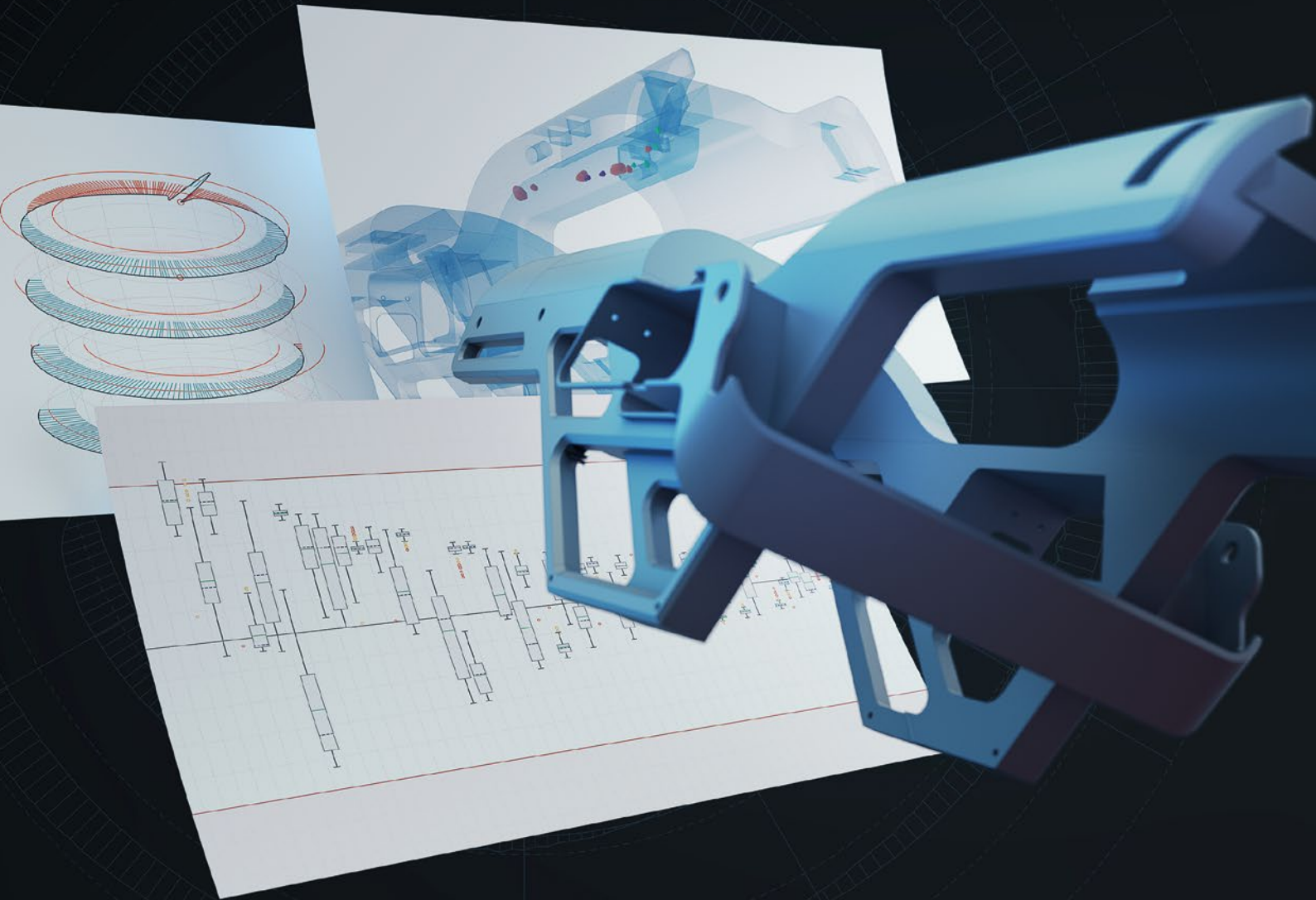

ZEISS PiWeb is a quality data management solution that bridges the gap between metrology results and shop floor actions. By consolidating metrology data from tactile, optical, manual, and CT measurements, PiWeb provides a comprehensive view of production quality, accessible in real-time from anywhere. With its interactive visualizations and statistics, PiWeb supports rapid, informed decisions and improves the ability to monitor and optimize measurement and manufacturing processes.



# ZEISS Services and Support

As a comprehensive solutions provider, ZEISS remains at your side independent of the purchase of a measuring system. From measuring services and training to enhanced application support – only ZEISS Industrial Quality Solutions is able to offer you the right expertise at all stages of the product life cycle.

We offer customized service packages, tailored to the needs of our customers and serve our customers through a highly skilled, global network of technicians. Equipped with enhanced digital tools and technologies, we are able to help our customers maximize their machine uptime, increase equipment utilization efficiencies and thereby resulting in better customer satisfaction.



### ZEISS QEC

Local Customer Center  
 Measurement Services  
 Quality Excellence Center  
 64 QECs in 38 Countries



### Knowledge

Training & Learning  
 AUKOM  
 ZEISS Academy  
 100+ Courses  
 38 Countries



### Maintenance & Repair

Service Contracts  
 Software Maintenance  
 Calibration Service  
 Customized HW/SW SMA  
 100K+ iBase  
 1200+ FSEs with  
 "Global Service Network"



### Retrofit & Productivity

Modernize Systems  
 Accessories  
 Monitor & Analyse  
 ZEISS Metrology Shop  
 B2B / Online  
 15K+ Products

## QUALITY EXCELLENCE CENTER

Measuring services in your area

Experience our broad portfolio of measuring services in our more than 60 locations worldwide. We offer a solution for your toughest measuring challenge so that you can focus on your core business.



## KNOWLEDGE

I am the solution.

The ZEISS ACADEMY METROLOGY offers online and classroom training tailored to your needs. Receive the most up-to-date knowledge and become an indispensable asset in your company: become the solution.



## MAINTENANCE & REPAIR

Customised Service Packages to Ensure Maximum Performance

Customized ZEISS Metrology Care packages, Software Maintenance Agreements and on-site Calibration services to unlock maximum performance, help avoid machine downtime and ensure trustworthy measurement results everytime. Real time monitoring, analysis and central overview with digital solutions.



## RETROFIT & PRODUCTIVITY

Performance Upgrade, Accessories and Digital Solutions

Upgrade your old machine to latest hardware and software standards for higher performance, more functionality at a fraction of cost of a new machine. ZEISS accessories solution for optimal precision and accuracy. Real time monitoring, analysis and central overview with digital solutions.

## METROLOGY PORTAL

One link. One login. One stop.

From software download, to the webshop to the ZEISS community – our online portal offers digital services that simplify your daily life in quality assurance.





Seeing beyond

**Carl Zeiss**  
**IQS Deutschland GmbH**  
73447 Oberkochen, Germany  
Phone: +49 7364 20-6337  
info.metrology.de@zeiss.com  
www.zeiss.de/imt

**Carl Zeiss**  
**Industrial Quality Solutions LLC**  
6250 Sycamore Lane North  
Maple Grove, MN 55369/USA  
Phone: +1 763 744-2400  
info.metrology.us@zeiss.com  
www.zeiss.com/metrology

[zeiss.ly/gxcm](https://zeiss.ly/gxcm)

