

ZEISS Gear Metrology







Specifications

Last updated: 2025-11



Seeing beyond

Gear types and variants

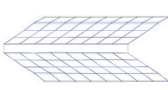
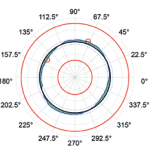
Gear types	Variants	Software solution
 <p>Cylindrical gears</p>	Involute profiles and splines Spur and helical gears External and internal gears Gear segments	GEAR® PRO involute basis
 <p>Special involute gears</p>	Conical gears Beveloids Sector shafts	GEAR® PRO involute advanced ¹⁾
 <p>Non-involute gears</p>	Linear profiles and non-involute splines Serrations Parallel key splines Straight transversal profiles (e.g. cycloids, sprockets)	GEAR® PRO involute advanced ¹⁾
 <p>Bevel gears</p>	Spiral and straight bevel gears Pinions and ring gears Bevel dies	Nominal data based on Master gear method (digitalization) or CAD model Nominal data imported via interface Gleason interface Klingelnberg interface DMG MORI interface
 <p>Worm gears</p>	Worm shafts with flank forms ZI ZA ZN ZK	GEAR® PRO worm basis
 <p>Rotors/ Screw compressors</p>	Male rotors Female rotors Straight rotors	GEAR® PRO rotor basis
 <p>Gear hobs</p>	One- and multiple-thread gear hobs for production of involute gears Fullprofile gear hobs (with or without turning plates technology)	GEAR® PRO hob basis GEAR® PRO hob advanced ¹⁾
 <p>Special gears</p>	Topographical evaluation of e.g. hirth gearings, worm wheels by nominal data based on Master gear method (digitalization) or CAD model	GEAR® PRO bevel basis
 <p>GPS evaluation</p>	GPS evaluations (geometrical product specifications) e.g. diameter, roundness, runout	CALYPSO basis
<p>Other gears and tools</p>	Customized solutions for e.g. gear racks on request	CALYPSO basis CALYPSO curve ¹⁾

1) Option, requires related basis package.

Features of the GEAR® PRO product family from ZEISS

Evaluation parameters (in extracts for cylindrical gears)	Profile ($F_{a'}$, $f_{fa'}$, $f_{Ha'}$) Helix ($F_{\beta'}$, $f_{f\beta'}$, $f_{H\beta'}$) Pitch ($F_{p'}$, $f_{fp'}$, $f_{ur'}$, $F_{pz/B}$) Runout (F_r) Tooth thickness parameters (S_s , $M_{rk'}$, $M_{dR'}$, $M_{dK'}$, W_k) Diameters ($d_{a'}$, d_f) Reliefs ($C_{aa'}$, $C_{a'}$, $C_{\beta'}$, $C_{BlI'}$) Crownings ($C_{\alpha'}$, C_{β}) Slope modifications ($C_{Ha'}$, $C_{H\beta}$) K-Diagram/Tolerance band Design profile, Design helix
Navigation (travel paths)	Automatic generated travel paths/navigation and stylus selection for measurement with and without rotary table (also for horizontal orientation)
Evaluation standards	ISO, DIN, ANSI, AGMA, JIS, several company standards
CAD capability	Visualization, software simulation, nominal data definition for e.g. bevel gears, rotors, special gears
Offline version	GEAR® PRO offline basis for creating offline measurement programs, simulation, later evaluation
Interfaces (all types)	PDF export, ASCII export, Q-DAS ASCII transfer format export ¹⁾ , CAD import/export (SAT, STEP, IGES)
Interfaces (cylindrical gears) ¹⁾	GDE import/export
Interfaces (bevel gears) ¹⁾	Gleason, Klingelnberg, DMG MORI
Non-contact evaluations	VOXEL data, STL data
Simulations ¹⁾	Virtual gauging effective tooth thickness/gap width, Actual-Actual comparison, single flank composite testing, order spectrum, color-coded topography

Supported systems and measuring methods of the GEAR® PRO product family from ZEISS

Systems	Bridge CMMs Shop Floor CMMs Large CMMs Multisensor CMMs Systems for Computed Tomography Systems for 3D digitizing	ZEISS CONTURA, ZEISS MICURA, ZEISS SPECTRUM, ZEISS SPECTRUM verity, ZEISS PRISMO, ZEISS PRISMO fortis, ZEISS PRISMO ultra, ZEISS PRISMO verity, ZEISS XENOS ZEISS DuraMax ZEISS MMZ G, ZEISS MMZ M, ZEISS MMZ T ZEISS O-INSPECT ZEISS METROTOM (VOXEL-data, STL-data) ZEISS ATOS (STL-data)	
Gear measuring methods	Without rotary table 3-axis scanning Various active and passive probing systems as well as articulating probing systems supported ²⁾ Horizontal orientation supported ³⁾ Pallet measurement supported ³⁾	With rotary table 3-axis and 4-axis scanning Various active and passive probing systems supported ²⁾ Clamping between centers with tailstock ZEISS TS supported ²⁾	
Probing systems	Active probing systems ZEISS VAST gold  ZEISS VAST XT gold  ZEISS VAST XTR gold 	Passive probing systems ZEISS VAST XXT  ZEISS VAST XXT at ZEISS RDS ⁴⁾ 	Non-contact probing systems ZEISS DotScan at ZEISS RDS ⁵⁾ 

1) Option, requires related basis package.

2) Depending on CMM type.

3) Not available for GEAR® PRO hob.

4) Only rotational axis (A axis) supported.

5) Non-contact measurement with chromatic confocal probing system only in combination with rotary table possible. Only available for GEAR® PRO involute.



Application examples

Gear measuring methods	Without rotary table		With rotary table
	Stylus system with single stylus (-Z orientation)	Stylus system with multiple styli or probing system with rotational axis and stylus system with single stylus	Stylus system with single stylus (side styli XY orientation)
			
Cylindrical gears			
Bevel gears			
Worm gears	Not applicable		
Rotors/ Screw compressors	Not applicable		
Gear hobs	Not applicable	Not applicable	

Gear geometry specifications

Min. module	$\geq 0.5 \text{ mm}^{1)}$		
Max. workpiece weight	Without rotary table	See CMM specifications (workpiece weight)	
	With rotary table	See rotary table specifications (permissible loading (axial) and max. mass moment of inertia) ²⁾	
		External gears	Internal gears
Max. workpiece length ³⁾	Vertical orientation	\leq Measuring range Z axis (G106)	$\leq 0.5 \times$ Measuring range Z axis (G106)
	Horizontal orientation	\leq Measuring range Y axis (G105)	$\leq 0.5 \times$ Measuring range Y axis (G105)
Max. workpiece diameter ³⁾	Vertical orientation	\leq Measuring range X axis (G104) - $L_{\text{StylusSystem}}$	\leq Measuring range X axis (G104)
	Horizontal orientation	\leq Measuring range Z axis (G106) - $L_{\text{StylusSystem}}$	\leq Measuring range Z axis (G106)

Comparison maximum workpiece diameter in relation to the different gear measuring methods

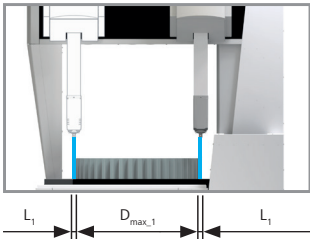
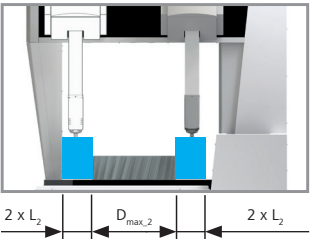
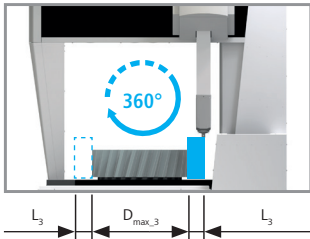
Gear measuring methods	Without rotary table		With rotary table
	Stylus system with single stylus (-Z orientation)	Stylus system with multiple styli or probing system with rotational axis and stylus system with single stylus	Stylus system with single stylus (side styli X/Y orientation)
			
Example	$D_{\text{max}_1} \leq (G104) - L_{\text{StylusSystem}_1}$ $L_{\text{StylusSystem}_1} = 2 \times L_1$ $L_1 \geq 5 \text{ mm}$ for module 3.5 mm ⁵⁾	$D_{\text{max}_2} \leq (G104) - L_{\text{StylusSystem}_2}$ $L_{\text{StylusSystem}_2} = 4 \times L_2$ $L_2 \geq 100 \text{ mm}$ for module 3.5 mm ⁵⁾	$D_{\text{max}_3} \leq (G104) - L_{\text{StylusSystem}_3}$ ⁴⁾ $L_{\text{StylusSystem}_3} = 2 \times L_3$ $L_3 \geq 100 \text{ mm}$ for module 3.5 mm ⁵⁾
			

1) No software limitation, smallest/largest module is depending on each individual gear geometry and the smallest/largest permissible stylus tip diameter of the selected probing system.

Module $\geq 0.5 \text{ mm}$ normally always measureable, module $< 0.5 \text{ mm}$ has to be verified regarding accessibility and permissible stylus tip diameter.

2) Values of permissible loading and max. mass moment of inertia have to be considered incl. clamping fixtures (e.g. chuck) and faceplate.

3) G 104 (measuring range X axis), G 105 (measuring range Y axis), G 106 (measuring range Z axis) acc. to the CMM specifications.

Stylus system dimensions and clamping fixtures (e.g. chuck) have to be considered for max. workpiece dimensions.

Typically the stylus system for the measurement without rotary table requires more measuring range of the CMM than the measurement with rotary table.

4) The max. diameter of a workpiece on a system with rotary table has to be less or equal to the faceplate of the rotary table.

5) Typical values for stylus system. May vary in individual cases.

Gear Accuracy

Measuring-instrument group VDI/VDE 2612 part 6:2022-05	A+ ¹⁾	A	B		C			D	
Tolerance class to be tested according to ISO 1328-1:2013-09	≤ 3	4	5	6	7	8	9	10	11
Recommended systems with active probing systems ²⁾	ZEISS PRISMO ultra ZEISS XENOS								
	ZEISS PRISMO ZEISS PRISMO fortis ZEISS PRISMO verity ZEISS MICURA			ZEISS CONTURA ZEISS MMZ G ZEISS MMZ M ZEISS MMZ T ZEISS SPECTRUM verity					
Recommended systems with passive probing systems ²⁾					ZEISS CONTURA ZEISS DuraMax ZEISS MMZ G ZEISS MMZ M ZEISS MMZ T ZEISS O-INSPECT ZEISS SPECTRUM ZEISS SPECTRUM verity				

1) For the measuring-instrument group (A+), no recommendations for maximum permissible errors (MPE) can be established according to the current state of the art, taking into account the measurement uncertainty. For accuracies in tolerance class 3 (ISO 1328-1:2013-09), it is currently not possible to consistently assign a measuring-instrument group. Individual maximum permissible errors shall be defined separately here between the manufacturer and the purchaser.

2) Profile and helix acceptance test can be performed with a gear artifact $z = 30$, $m = 3.5$ mm, $d = 105$ mm, $\alpha = 20^\circ$, $\beta = 0^\circ / 20^\circ$ r / 20° l, $b = 70$ mm (or similar gear artifact).
Pitch and runout acceptance test can be performed with a gear artifact $z = 30$, $m = 3.5$ mm, $d = 105$ mm, $\alpha = 20^\circ$, $\beta = 0^\circ$, $b = 30$ mm (or similar gear artifact).

Carl Zeiss

Industrielle Messtechnik GmbH

73446 Oberkochen / Germany

Sales: +49 7364 20-6336

Service: +49 7364 20-6337

Fax: +49 7364 20-3870

Email: info.metrology.de@zeiss.com

Internet: www.zeiss.de/imt

Carl Zeiss

Industrial Metrology, LLC

6250 Sycamore Lane North

Maple Grove, MN 55369/USA

Phone: +1 763 744-2400

Fax: +1 763 533-0219

Email: info.metrology.us@zeiss.com

Internet: www.zeiss.com/metrology